

# COSTELLAZIONI



# La nostra mission è realizzare porte eccellenti che entreranno a far parte delle case arredate col migliore stile e gusto.

*Our mission is to make excellent doors that will feature in the most tastefully and stylishly decorated houses.*

I nostri clienti sono tutti importanti e dedichiamo tutto il nostro impegno, ogni giorno, per dar loro un prodotto dalla qualità superiore con costi accessibili. Prestiamo la massima attenzione alle aspettative dei nostri clienti, che sognano, progettano ed immaginano la loro casa, in cui investono tempo e risorse. È per noi motivo di grande orgoglio far parte di quei sogni.

Il nostro cliente è colui che ci consente ogni giorno di creare nuovi posti di lavoro, innovare ed investire ogni nostra risorsa per migliorare e far crescere il nostro brand nel mondo.

Le porte per noi, non sono semplici oggetti, ma creazioni di abiti sartoriali "su misura" che dovranno calzare nella casa dei nostri clienti rasentando il limite della perfezione.

Ci pregiamo del marchio Made in Italy e lo siamo in ogni componente, nella materia prima, nel design e nella produzione: tutto il nostro prodotto è creato e realizzato in Italia.

Le originali Bertolotto. È la sintesi del nostro modo di lavorare e del nostro successo.

Tutto questo grazie alla fiducia dei nostri clienti, oltre 1,5 milioni di famiglie sparse in oltre 40 paesi del mondo.

*All our customers are very important people and our daily energies are all focused on providing them with a superior quality product at an affordable price. We pay the utmost attention to our customers' expectations: they dream, plan and imagine their homes where they invest their time and resources. We are very proud to be a part of those dreams. For us a client is a person who allows us to create new jobs, innovate and invest all our resources on a daily basis so that we can improve our brand and spread it throughout the world. For us doors are not just objects, they are rather "made-to-measure" one-off creations that will perfectly fit our customers' houses and will reach out almost the perfection. We are honored to have a Made in Italy brand that concerns all the components, from raw materials to design and manufacturing: our product is entirely designed and manufactured in Italy. Original Bertolotto doors are the synthesis of the way we work and why we are successful. All of this thanks to the fact that customers trust us and they are more than 1.5 million households located in over 40 countries throughout the world.*

Ceo  
Bertolotto SpA  
Claudio Bertolotto

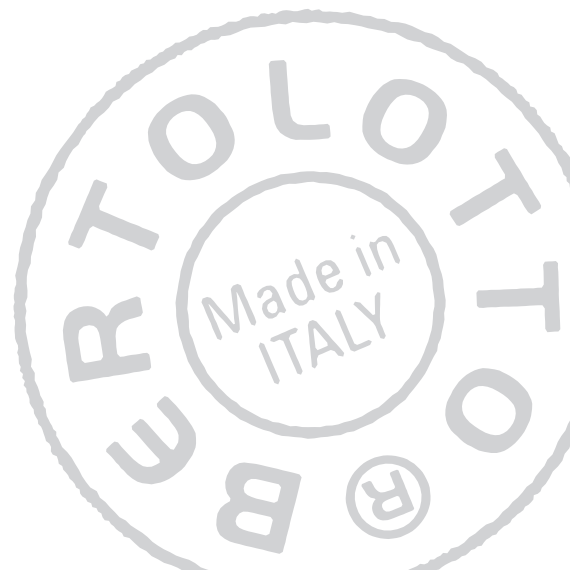



# Le Originali Bertolotto®

Autentica creatività Made in Italy.

Nelle porte Bertolotto troverete l'unicità e la personalità di un pensiero creativo, tutto italiano, fondato sul sapere artigiano di quasi 30 anni di esperienza che dà vita alla più ampia collezione di porte per interni di sempre. Il sigillo apposto su ogni porta attesta l'autenticità e l'originalità del prodotto Bertolotto Porte.

## *Italian LifeStyle*

*“Le Originali Bertolotto” sono pensate per un pubblico che vuole circondarsi di cose belle e desidera arredare la propria casa con soluzioni capaci di esprimere valori duraturi.*



Authentic creativity made in Italy.

*In Bertolotto's doors you will find the uniqueness and the personality of a creative thought, all Italian, founded on handmade knowledge that gives life to the largest collection ever done of interior doors. The seal affixed to each product confirms the authenticity and the originality of Bertolotto Porte's product.*

## *Italian LifeStyle*

*“Le Originali Bertolotto” are designed for an audience that wants to surround himself with beautiful things and want to furnish their home with solutions that express enduring values.*



# BERTOLOTTO

Solo porte dal 1988

LE MIGLIORI MATERIE PRIME, LA SAPIENZA ARTIGIANA DEI LAVORATORI CHE SI UNISCE ALLA TECNOLOGIA PIÙ AVANZATA DEI NOSTRI MACCHINARI, IL DESIGN ESCLUSIVO, LA RICERCA CONTINUA DI NUOVI MODELLI, COLORI E SOLUZIONI, LA SFIDA QUOTIDIANA PER MIGLIORARE LA QUALITÀ DEI NOSTRI PRODOTTI: QUESTE LE CARTE VINCENTI DELLA NOSTRA AZIENDA, CHE IN QUASI TRENTANNI È DIVENTATA LEADER IN ITALIA E NEL MONDO NEL SETTORE DELLE PORTE PER INTERNI. ARREDARE SIGNIFICA CREARE IL PROPRIO AMBIENTE. OGNI ELEMENTO DI ARREDO È L'UNIONE TRA IL GUSTO E LA QUALITÀ, PERCHÈ LA PORTA È UN PRODOTTO CHE RIMANE IN CASA PER TUTTA LA VITA.

PORTE IN LEGNO MASSELLO O IN MATERIALI HIGH TECH, INCISE, DIPINTE A MANO, CLASSICHE ISPIRATE ALLA TRADIZIONE ITALIANA O MINIMALISTE, MODERNE E DI TENDENZA. PORTE PER INTERNI, PORTE BLINDATE, PORTE TAGLIAFUOCO. DICHIOTTO COLLEZIONI, OTTANTA COLORAZIONI, DICHIOTTO ESSENZE, MIGLIAIA DI VARIANTI: OGNI PORTA CALZA A PENNELLO I DESIDERI, COME SE FOSSE UN ABITO SU MISURA.

*Solo porte dal 1988*

*THE FINEST WOOD, THE WISDOM OF OUR CRAFTSMEN COMBINED WITH CUTTING EDGE TECHNOLOGY, EXCLUSIVE DESIGN AND OUR CONSTANT SEARCH FOR NEW LINES, COLOURS AND FINISHES ARE THE ELEMENTS THAT MAKE OUR COMPANY A LEADER IN THE FIELD OF INTERIOR DOORS, BOTH IN ITALY AND WORLD-WIDE. FURNISHING MEANS CREATING YOUR OWN ENVIRONMENT, WHERE EACH PIECE UNITES GOOD TASTE AND QUALITY, BECAUSE DOORS ARE A PRODUCT THAT STAY IN YOUR HOME FOR A LIFETIME. SOLID WOOD DOORS OR HIGH TECH MATERIALS, ENGRAVED, HAND-PAINTED, CLASSICAL LOOKS INSPIRED BY THE ITALIAN TRADITION OR MINIMALIST, MODERN AND TRENDY. INTERNAL DOORS, REINFORCED DOORS, FIREDOORS. EIGHTEEN COLLECTIONS, EIGHTY COLOURS, EIGHTEEN VENEERS, THOUSANDS OF OPTIONS: A DOOR TO SUIT YOUR EVERY NEED.*

## Costellazioni

LA VOLTA CELESTE E ALCUNE DELLE SUE STELLE PIÙ LUMINOSE ISPIRANO IL DESIGN DI ALTAIR, CASSIOPEA, AURIGA, PEGASO, ANDROMEDA, VEGA. LINEE, CERCHI, GEOMETRIE SI FONDONO COL MITO. OGNI PORTA APRE UN PASSAGGIO VERSO IL CIELO: BASTA SOGNARE. (DA UN'IDEA DI ELIO GARIS, IN ESCLUSIVA PER BERTOLOTTO PORTE S.p.A.). COSTELLAZIONI, LA RAFFINATEZZA SILENZIOSA CHE DURA 30 ANNI IN CASA VOSTRA.

*THE PALE BLUE VAULT AND SOME OF ITS STARS INSPIRE THE DESIGN OF ALTAIR, CASSIOPEA, AURIGA, PEGASO, ANDROMEDA, VEGA. LINES, CIRCLES, GEOMETRIES FUSE TOGETHER WITH MYTH. EVERY DOOR OPENS THE WAY TO THE SKY: YOU HAVE JUST TO DREAM (THIS IS AN ELIO GARIS IDEA JUST FOR BERTOLOTTO PORTE). COSTELLAZIONI IS THE SILENT REFINEMENT THAT WILL LAST 30 YEARS IN YOUR HOME.*



# UNA LACCATURA SUPERIORE, NON A PAROLE, MA CON I FATTI, CERTIFICATI !!!

*HIGH-QUALITY LACQUERING, NOT IN WORDS BUT IN DEEDS, CERTIFIED !!!*



L'INTERA GAMMA È PROPOSTA IN TUTTI I COLORI RAL E NCS: LACCATURE DI ALTA QUALITÀ, REALIZZATE CON DIVERSI STRATI DI VERNICE ALL'ACQUA. FINITURA OPACA, LUCIDA AL POLIESTERE O SPAZZOLATA A PORO APERTO, PER EVIDENZIARE LA VENATURA DEL LEGNO.

THE FULL RANGE IS PROPOSED WITH RAL AND NCS COLORS: HIGH-QUALITY LACQUERING, CREATED WITH DIFFERENT LAYERS OF WATER-BASED PAINT: MATT AND GLOSSY FINISH IN POLYESTER OR BRUSHED OPEN PORE, IN ORDER TO UNDERLINE THE WOOD GRAIN.

I NOSTRI PRODOTTI LACCATI SUPERANO I TEST PIÙ AGGRESSIVI PER LA RESISTENZA ALL'ABRASIONE E ALL'AZIONE DEI DETERGENTI.

OUR LACQUERED PRODUCTS OVERCOME THE MOST AGGRESSIVE TESTS FOR ABRASION RESISTANCE AND CLEANING ACTION.

LE LACCATURE BERTOLOTTO SONO VERIFICATE DAL CATAS (CENTRO RICERCHE E SVILUPPO E LABORATORI PROVE SETTORI LEGNO-ARREDO, AMBIENTE E ALIMENTI).

BERTOLOTTO LACQUERINGS ARE CHECKED BY CATAS (ITALIAN RESEARCH AND CERTIFICATION INSTITUTE AND TEST LABORATORY IN THE WOOD AND FURNITURE FIELD AS WELL AS IN THE AGRICULTURAL AND FOOD SECTOR).

- RESISTENZA DELLE SUPERFICI AI LIQUIDI FREDDI EN 12720:2013
- RESISTENZA AI LIQUIDI FREDDI (PRODOTTI DI PULIZIA) PTP 53:1995
- PROVA DI USURA MEDIANTE SFREGAMENTO - PTP CATAS

- SURFACE RESISTANCE TO COLD LIQUIDS (EN 12720:2013)
- RESISTANCE TO COLD LIQUIDS - CLEANING PRODUCTS (PTP 53:1995)
- WEAR TEST BY RUBBING (PTP CATAS)

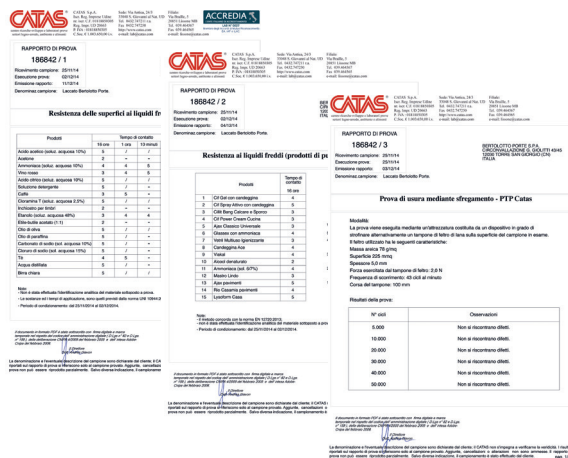

## LA CERTIFICAZIONE FSC® THE CERTIFICATION FSC®

"LA CERTIFICAZIONE FSC® È UNA CERTIFICAZIONE INTERNAZIONALE, INDIPENDENTE E DI PARTE TERZA, SPECIFICA PER IL SETTORE FORESTALE E I PRODOTTI - LEGNOSI E NON LEGNOSI - DERIVATI DALLE FORESTE. NEI SUOI 20 ANNI DI ATTIVITÀ FSC® SI È CONQUISTATA LA REPUTAZIONE DI SISTEMA DI CERTIFICAZIONE FORESTALE CREDIBILE E RIGOROSO. ECCO PERCHÉ ACQUISTARE PRODOTTI CERTIFICATI FSC® HA INNUMEREVOLI VANTAGGI, PER LE AZIENDE E PER I CONSUMATORI."

DAL SITO [WWW.FSC.ORG](http://WWW.FSC.ORG)

**CERTIFICATE**  
Number: BV-COC-122285

Issued 17 March, 2016  
Valid until 17 March, 2021

Bureau Veritas Certification certifies that the company:  
**BERTOLOTTO PORTE SPA**  
Via Capotrasone, 15 - 02045 - CIVITANOVA (VT) - ITALY  
12000 - TORRE SAN GIOVANNI - ITALY

for its activities concerning:  
Doors and door frames FSC 100%, FSC Mix or FSC Recycled certified \*  
Porte ad infissi di porte certificate FSC 100%, FSC Mix o FSC Riciclate \*

This company has been assessed and found to conform to the requirements of:  
FSC Chain of Custody Certification standard, Ref: FSC-COC-40-004 V3-1

This certificate is valid for a 5 years period.  
Over-certification is prohibited.

Witnessed on 17 March, 2016  
Bureau Veritas Certification  
Anna NICOLELLA

"THE CERTIFICATION FSC® IS AN INTERNATIONAL, INDEPENDENT AND THIRD PARTY CERTIFICATION. IT IS SPECIFIC FOR THE FORESTRY SECTOR AND THE WOOD AND NON-WOOD PRODUCTS DERIVED FROM THE FORESTRY. DURING ITS 20 YEARS OF WORK, THE FSC® CERTIFICATION GAINED THE REPUTATION OF CREDIBLE AND RIGOROUS FORESTRY CERTIFICATION SYSTEM. THIS IS THE REASON WHY THERE ARE LOTS OF ADVANTAGES TO BUY PRODUCTS CERTIFICATED FSC® BOTH FOR THE COMPANIES AND FOR THE CONSUMERS".

[WWW.FSC.ORG](http://WWW.FSC.ORG)









# Design di ELIO GARIS

NATO A VIGONE (TO) NEL 1954, DOVE VIVE E LAVORA. DOPO LA MATURITÀ ARTISTICA INIZIA A DIPINGERE ED ESPONE PER LA PRIMA VOLTA, CON UNA PERSONALE, NEL 1975 PRESSO LA GALLERIA FLORIANA DI COSSATO, BIELLA. IN SEGUITO FREQUENTA UN CORSO DI DISEGNO ANATOMO-CHIRURGICO E UN CORSO DI CERAMICA IN FRANCIA. ALTERNA L'ATTIVITÀ DI CERAMISTA A QUELLA DI PITTORE FINO AL 1978, ANNO IN CUI REALIZZA LA BOTTEGA DI MASTRO MAHEL; UN'OFFICINA D'ARTE DOVE SI SPERIMENTANO TECNICHE E MATERIALI VARI, LUOGO DI INCONTRO PER ARTISTI PROVENIENTI DA VARIE ESPERIENZE ESPRESSIVE.

NEL 1984 VIENE SCELTO DALLA J. C. PENNY DI NEW YORK CON ALTRI 54 ARTIGIANI, PER RAPPRESENTARE L'ARTIGIANATO ITALIANO NEGLI STATI UNITI D'AMERICA. LAVORA A DALLAS, KANSAS CITY, ST. LOUIS E NEW YORK. NEL 1988, CON LA MOSTRA PERSONALE PRESSO L'EX PALAZZO COMUNALE DI MONDOVÌ, INAUGURA IL PERIODO DELLE "SABBIE" E DEI "VETRI". DAL 1989 AL 2011 REALIZZA 28 OPERE PUBBLICHE USANDO MATERIALI DIVERSI QUALI: BRONZO, MARMO, CEMENTO, ACCIAIO INOX, ACCIAIO CORTEN, GHISA E LEGNO. LE ULTIME MOSTRE PERSONALI SONO STATE ALLA GALLERIA CHARLICK E PIERO PASSET DI LONDRA (1999,2000,2001,2003,2005), ALLE GALLERIE LOSANO E STORELLO DI PINEROLO, GALLERIA LA NAVE DI GRUGLIASCO (2006) A CURA DI PATRIZIA BOTTALLO, È STATO INVITATO A PARTECIPARE ALLA SESTA BIENNALE (A CURA DI LUCIANO CAMEL)" SCULTURA INTERNAZIONALE A RACCONIGI (2010).

NEL 2010 CON LA MOSTRA " DENTRO LA SCULTURA " AL MUSEO CLIZIA DI CHIVASSO (TO) , A CURA DI PATRIZIA BOTTALLO E DIEGO BIONDA,È STATO STAMPATO UN LIBRO MONOGRAFICO EDITO DA GRIBAUDDO. NEL 2013 INIZIA LA COLLABORAZIONE CON LA BAREL E NEL 2014 NE DIVENTA DIRETTORE ARTISTICO. DAL 2007 COLLABORA CON LA BERTOLOTTO PORTE S.P.A., SUE LE COLLEZIONI "CASA ZEN – COSTELLAZIONI – LE SFODERABILI".

*HE WAS BORN IN VIGONE (TURIN) IN 1954, WHERE HE CURRENTLY LIVES AND HE WORKS. AFTER THE ARTS HIGH SCHOOL DIPLOMA, HE STARTED TO PAINT AND FOR THE FIRST TIME, IN 1975, HE DISPLAYED HIS PERSONAL COLLECTION IN THE "FLORIANA GALLERY" OF COSSATO IN BIELLA. THEN, HE ATTENDED AN ANATOMY-SURGICAL DRAWING CLASS AND A CERAMICS CLASS IN FRANCE. SINCE 1978 HE WORKED BOTH AS A CERAMIST AND PAINTER. IN THAT PERIOD HE CREATED THE MASTER MAHEL'S WORKSHOP, A LABORATORY WHERE IT IS POSSIBLE USE AND TEST DIFFERENT TECHNIQUES AND MATERIALS THIS WAS ALSO A MEETING PLACE FOR ARTISTS WHO CAME FROM DIFFERENT EXPRESSIVE EXPERIENCES. IN 1984 HE WAS SELECTED FROM THE J.C. PENNY OF NEW YORK WITH 54 CRAFTSMEN, IN ORDER TO REPRESENT THE ITALIAN ARTCRAFT IN THE UNITED STATES OF AMERICA. HE WORKED IN DALLAS, KANSAS CITY, ST. LOUIS AND NEW YORK. IN 1988 INTRODUCED THE USE OF THE "SANDS" AND THE "GLASSES", THANKS TO HIS EXHIBITION DISPLAYED IN THE EX TOWN HALL OF MONDOVI. FROM 1989 TO 2011 HE CREATED 28 PUBLIC WORKS USING DIFFERENT MATERIALS SUCH AS: BRONZE, MARBLE, CONCRETE , COLOURLESS STEEL, CORTEN STEEL, CAST IRON, WOOD. THE LAST NATIONAL EXHIBITION WAS MADE AT THE "CHARLICK AND PIERI PASSET GALLERY" OF LONDON (1999,2000,2001,2003,2005), AT LOSANO E STORELLO GALLERY IN PINEROLO, AT "LA NEVE GALLERY" IN GRUGLIASCO (2006) EDITED BY PATRIZIA BOTTALLO. HE WAS ALSO INVITED TO PARTICIPATE TO THE 6TH BIENNIAL "INTERNATIONAL SCULPTURE IN RACCONIGI"- 2010 (EDITED BY LUCIANO CAMEL).*

*IN 2010, A MONOGRAPHIC BOOK PUBLISHED BY MR. GRIBAUDDO WAS PRINTED THANKS TO THE EXHIBITION "BEHIND THE SCULPTURE" IN THE "CLIZIA MUSEUM" OF CHIVASSO (TO), EDITED BY PATRIZIA BOTTALLO E DIEGO BIONDA. IN 2013 HE STARTED TO COOPERATE WITH "THE BAREL" AND IN 2014 HE BECAME ITS ARTISTIC DIRECTOR. HE HAS BEEN COOPERATING WITH BERTOLOTTO PORTE COMPANY S.P.A. SINCE 2007, IN FACT THE CASA ZEN COLLECTION, COSTELLAZIONI, SFODERABILI ARE ACTUALLY HIS CREATION.*



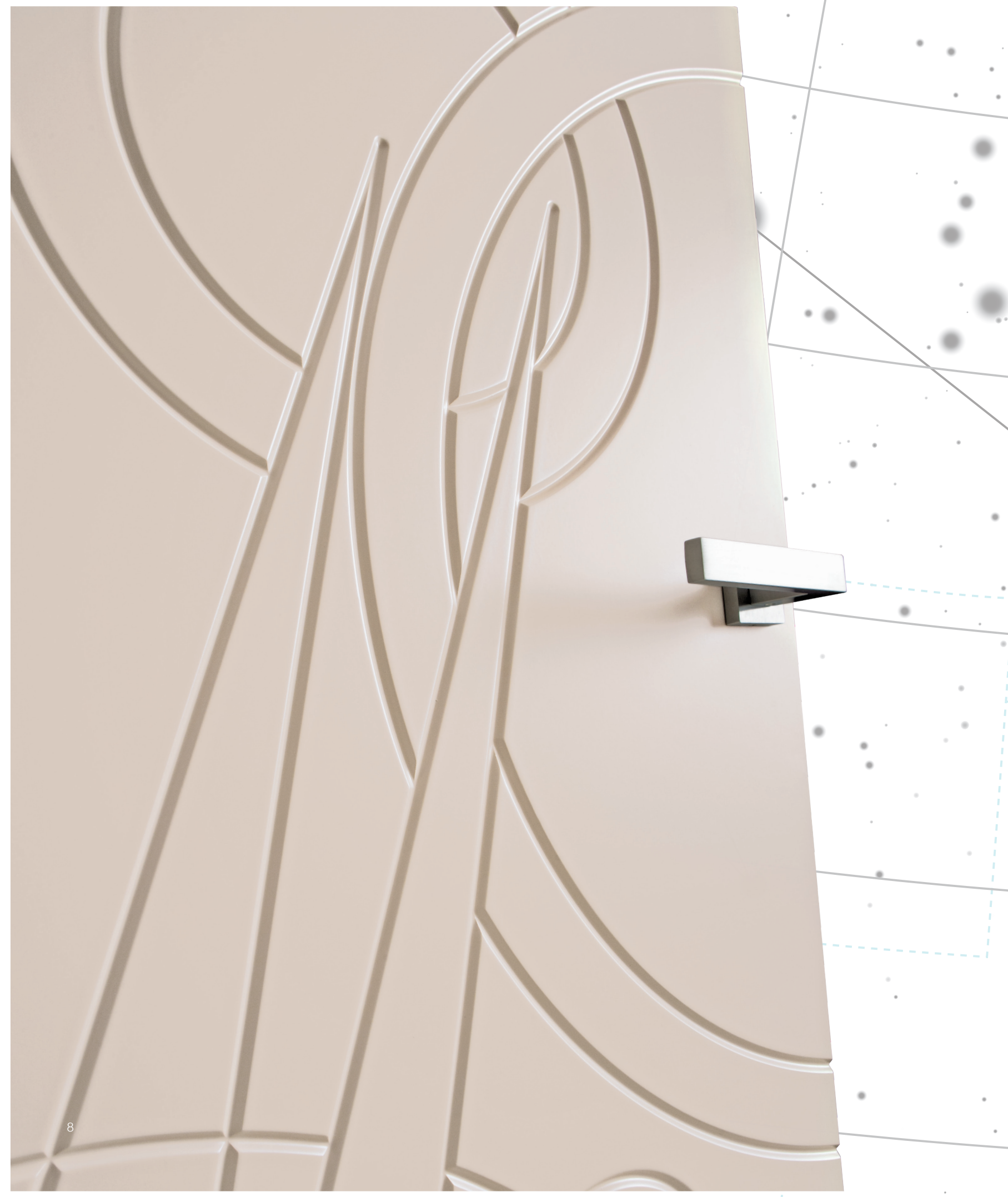



# PEGASO

TINTA

COLOUR

LACCATO CIPRIA

TELAIO

FRAME

T/SOR

MANIGLIA

HANDLE

BIBAO CROMO SATINATO

BATTISCOPIA

SKIRTING

B8 - LACCATO CIPRIA



MODELLO PEGASO

SCULTURA DI ELIO GARIS "MACCHINA PER 550x450x300 H" (1995) ferro ossidato e acciaio inox

SCULPTURE BY ELIO GARIS "MACCHINA PER 550x450x300 H" (1995) oxidised iron and stainless steel



# PEGASO

**TIPOLOGIA DI APERTURA**  
**OPENING SYSTEM**

BOISERIE INDIVIDUAL CON  
WALLDOOR

**TINTA**

**COLOUR**

LACCATO ROSSO

**MANIGLIA**

**HANDLE**

BILBAO CROMO SATINATO



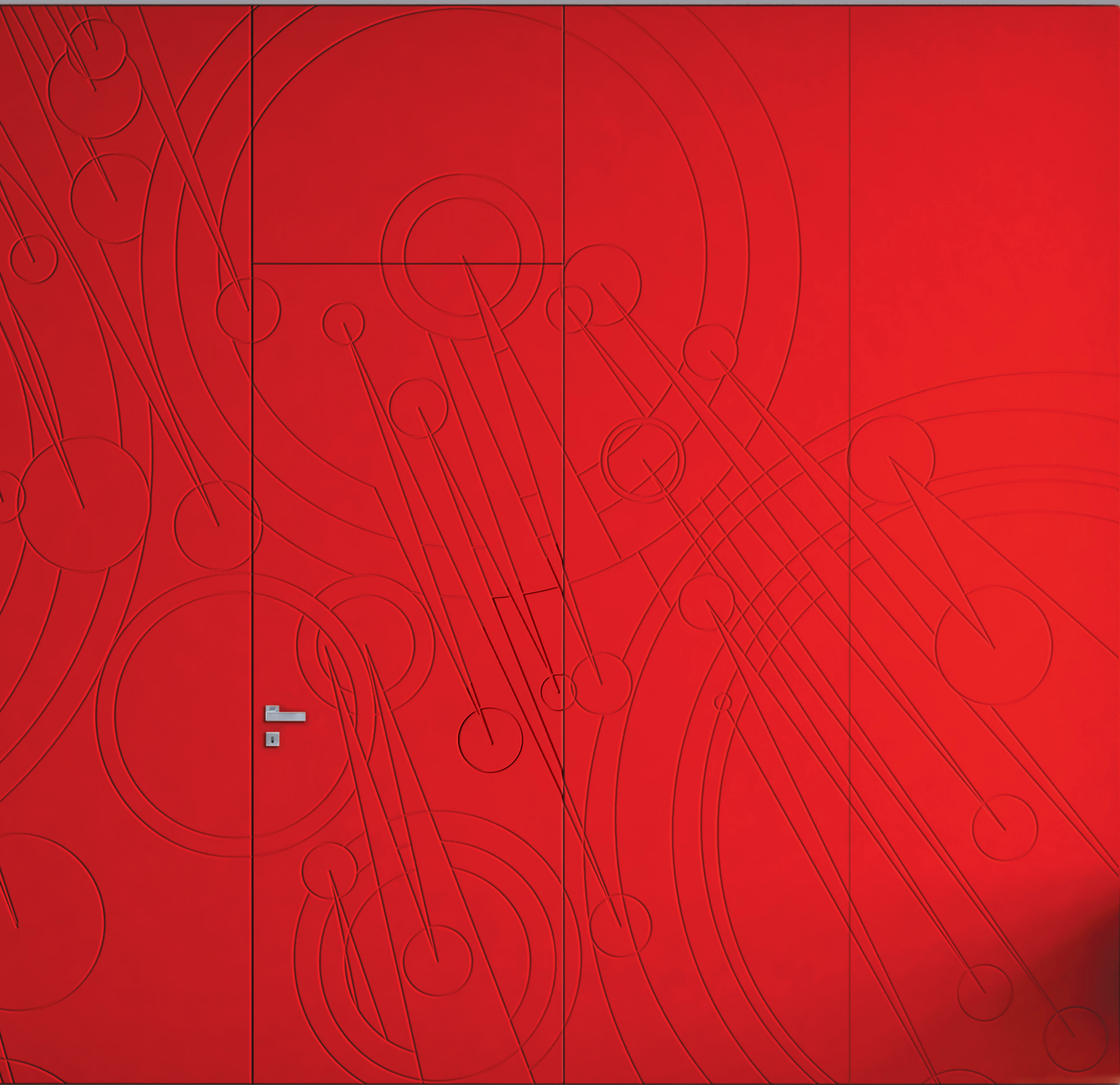







# PEGASO

**TINTA**  
**COLOUR**  
LACCATO AVORIO  
**TELAIO**  
**FRAME**  
TR/L8  
**MANIGLIA**  
**HANDLE**  
BILBAO CROMO SATINATO



SCULTURA DI ELIO GARIS "MACCHINA PER 550x450x300 H" (1995) ferro ossidato e acciaio inox  
SCULPTURE BY ELIO GARIS "MACCHINA PER 550x450x300 H" (1995) oxidised iron and stainless steel





UNNGHIATA INKA

CROMO SATINATO  
*FLUSH PULL INKA*



# PEGASO

**TIPOLOGIA DI APERTURA**

**OPENING SYSTEM**

SCORREVOLE PHANTOM

**TINTA**

**COLOUR**

LACCATO ROSSO

**UNGHIATA**

**FLUSH PULL**

INKA CROMO SATINATO



SCULTURA DI ELIO GARIS "MACCHINA PER 550x450x300 H" (1995) ferro ossidato e acciaio inox

SCULPTURE DI ELIO GARIS "MACCHINA PER 550x450x300 H" (1995) oxidised iron and stainless steel



# BOISERIE INDIVIDUAL

## TIPOLOGIA DI APERTURA

### OPENING SYSTEM

BOISERIE CON WALLDOOR

MASSIMA TUTTALTEZZA

## TINTA

### COLOUR

LACCATO LUCIDO BIANCO E RAL

## MANIGLIA

### HANDLE

BILBAO CROMO SATINATO

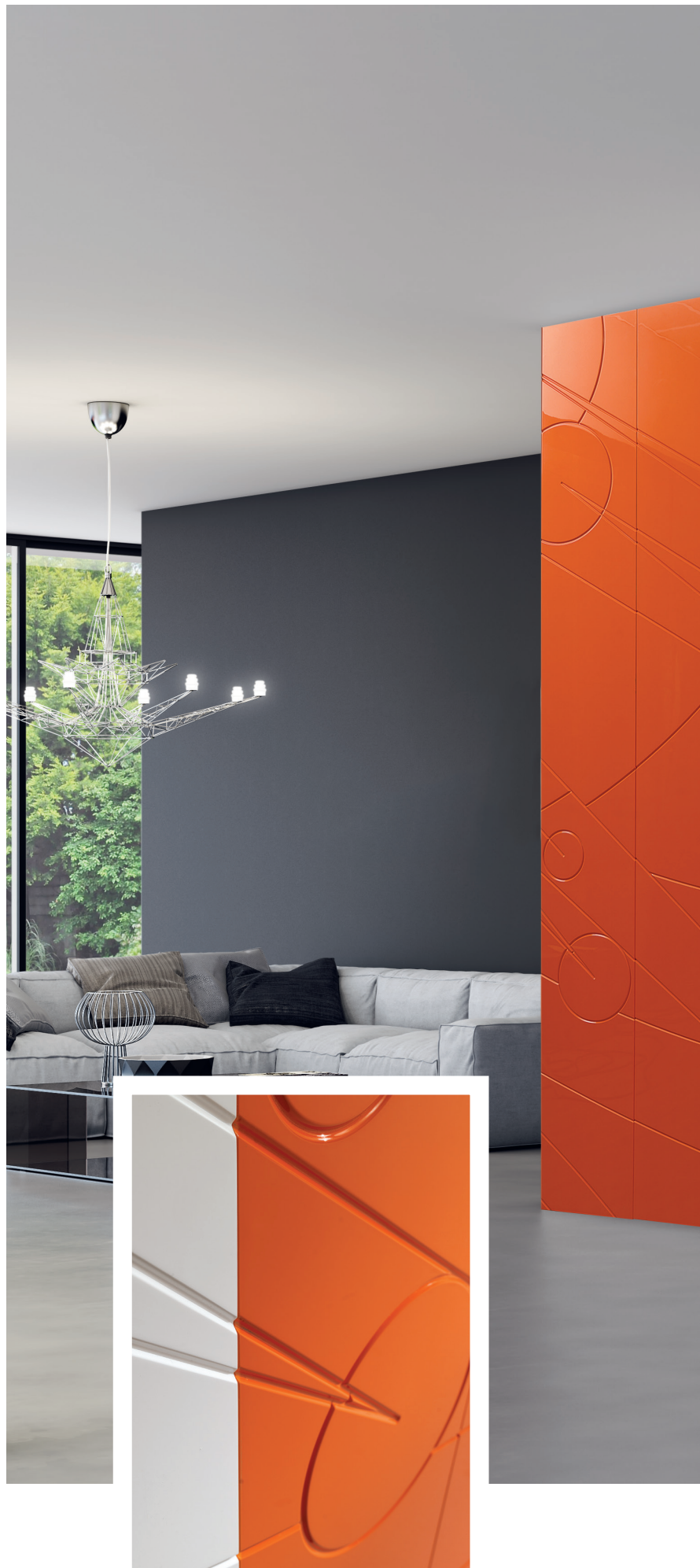





SCULTURA DI ELIO GARIS "TRIPODE" (2005) resina acrilica, cm. 60x50x190  
SCULPTURE BY ELIO GARIS "TRIPODE" (2005) acrylic resin, cm. 60x50x190





# ARMADIO INDIVIDUAL

DOPPIA ANTA

**TINTA**

**COLOUR**

LACCATO BIANCO

**POMOLO**

**KNOB**

A SCOMPARSA SPINGI/TIRA

TONDO





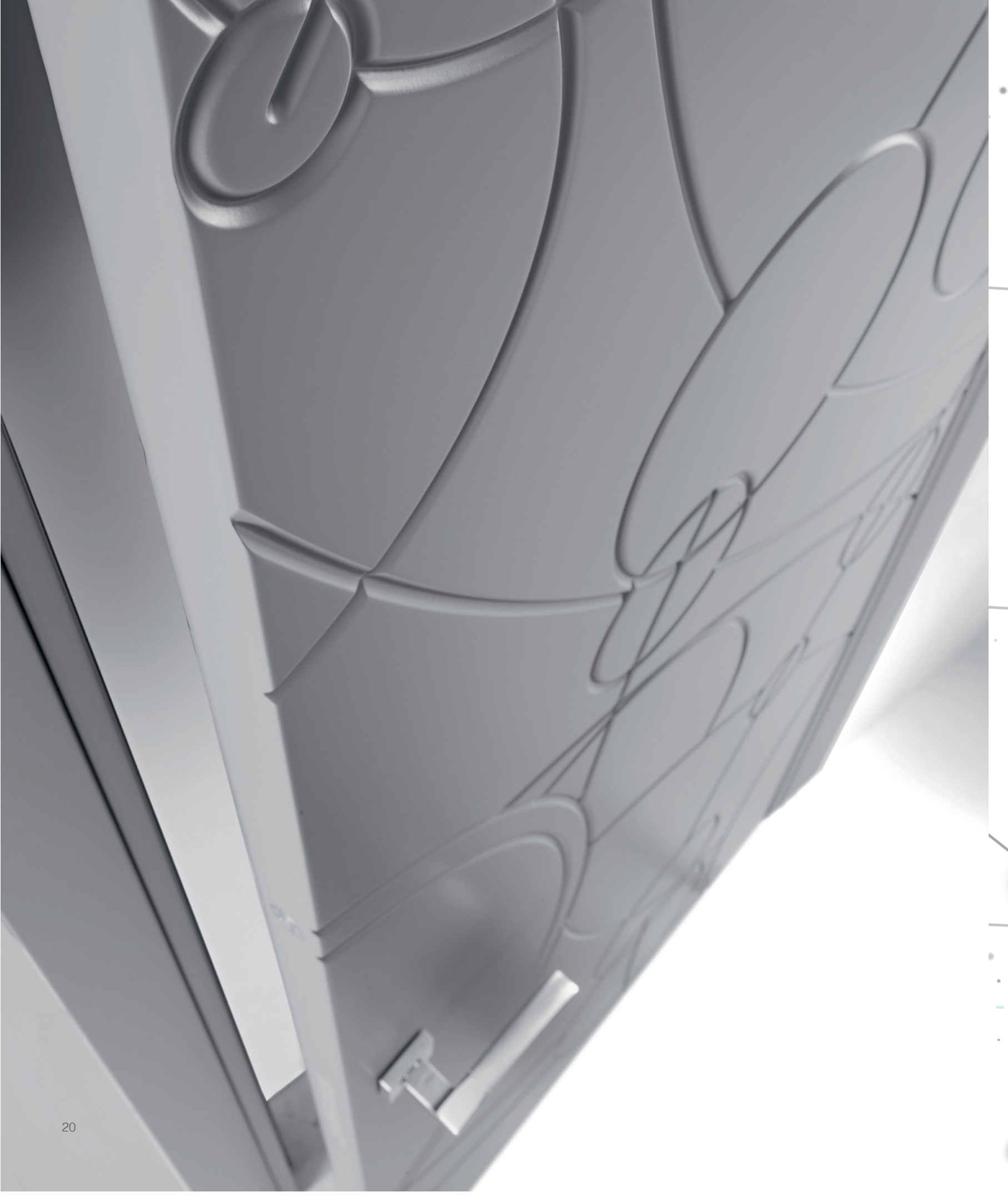



# ALTAIR

TINTA  
COLOUR  
LACCATO QUARZO  
TELAIO  
FRAME  
T/SOR  
MANIGLIA  
HANDLE  
PARROT CROMO LUC./SAT



MODELLO ALTAIR



# BOISERIE ALTAIR

## TIPOLOGIA DI APERTURA

### OPENING SYSTEM

BOISERIE CON WALLDOOR MINIMA

### TINTA

### COLOUR

LACCATO LUCIDO BIANCO

### MANIGLIA

### HANDLE

BILBAO CROMO SATINATO

COSTELLAZIONI NON È SOLO UNA PORTA, MA UN ELEMENTO DI ARREDO: RIVESTIRE UNA PARETE PER CARATTERIZZARE IN MANIERA FORTE UN AMBIENTE, PER SOTTOLINEARE UNO SPAZIO, PER RENDERLO UNICO.

*CONSTELLAZIONI IS NOT JUST A DOOR, BUT AN ITEM OF FURNITURE: YOU CAN UPHOLSTER THE WALL TO CHARACTERIZE IN A STRONG WAY THE ENVIRONMENT, TO EMPHASIZE A SPACE, TO MAKE IT UNIQUE.*









# ALTAIR INDIVIDUAL PLANA



IL SISTEMA SCORREVOLE PLANA E LA VERSIONE PLANA CON COVER SONO LA SOLUZIONE ELEGANTE E MINIMALE PER LE PORTE SCORREVOLI ANCHE DI GRANDI DIMENSIONI.

IL MOVIMENTO È FLUIDO E SILENZIOSO, CONFORTEVOLE.

*SLIDING PLANA SYSTEM AND PLANA WITH COVER VERSION ARE THE ELEGANT AND MINIMAL SOLUTION FOR SLIDING DOORS OF EVEN BIG DIMENSIONS.*

*THE MOVEMENT IS FLUID, SILENT AND COMFORTABLE.*



# ALTAIR INDIVIDUAL

**TIPOLOGIA DI APERTURA**

**OPENING SYSTEM**

SCORREVOLE PLANA,

BINARIO 2 VIE ESTERNO VANO

**TINTA/COLOUR**

LACCATO BIANCO

**UNGHIATA/FLUSH PULL**

INKA CROMO SATINATO



# 3151 INDIVIDUAL

**TIPOLOGIA DI APERTURA**

**OPENING SYSTEM**

SCORREVOLE PHANTOM

**VETRO**

**GLASS**

GRIGIO SATINATO INCISO

**MANIGLIONE**

**HANDLE**

LINEAR CROMO SATINATO





# ALTAIR

**TIPOLOGIA DI APERTURA**  
**OPENING SYSTEM**

SCORREVOLE PHANTOM

**TINTA**

**COLOUR**

LACCATO QUARZO

**MANIGLIONE**

**HANDLE**

LINEAR CROMO SATINATO



*SCULTURA DI ELIO GARIS "ELISSE" (2007) resina acrilica verniciata cm. 250x120x225 H*  
*SCULPTURE BY ELIO GARIS "ELISSE" (2007) painted acrylic resin cm. 250x120x225 H*



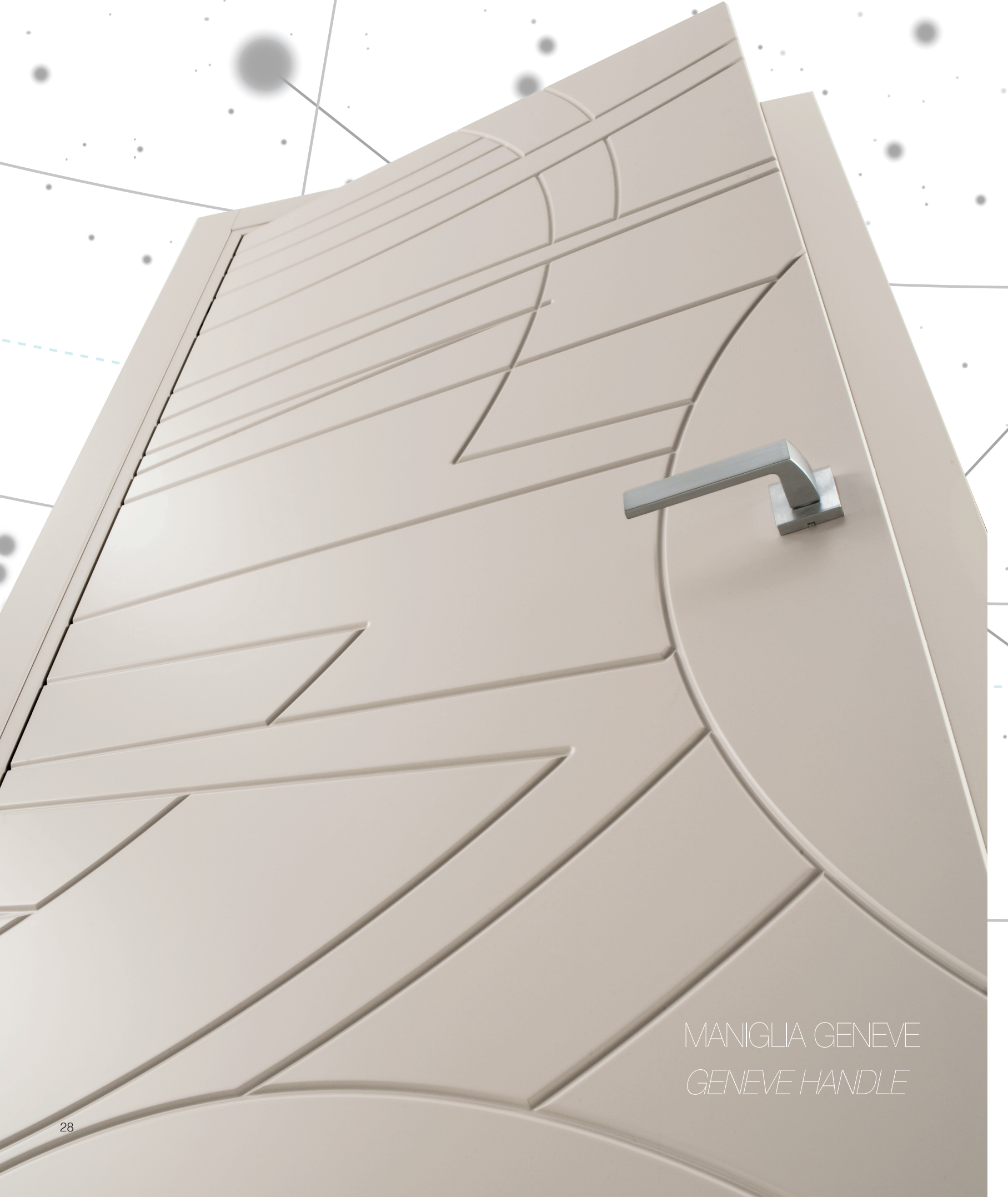

MANIGLIA GENEVE  
*GENEVE HANDLE*

# VEGA

**TINTA**

**COLOUR**

LACCATO SABBIA

**TELAIO**

**FRAME**

TR/L8

**MANIGLIA**

**HANDLE**

VIRGIN CROMO LUC./SAT.

CON ROSETTA MINI

**BATTISCOPIA**

**SKIRTING BOARD**

B8 - LACCATO SABBIA



# VEGA

# MODELLO







# VEGA

**TIPOLOGIA DI APERTURA**  
**OPENING SYSTEM**

SCORREVOLE WALLDOOR

**TINTA**

**COLOUR**

LACCATO BIANCO

**UNGIATA**

**FLUSH PULL**

INKA CROMO SATINATO





# VEGA

**TIPOLOGIA DI APERTURA**  
**OPENING SYSTEM**

BOISERIE INDIVIDUAL CON  
WALLDOOR

**TINTA**

**COLOUR**

LACCATO SABBIA

**MANIGLIA**

**HANDLE**

TOC CROMO SATINATO







SCULTURA DI ELIO GARIS "ELISSE" (2007) resina acrilica verniciata cm. 250x120x225 H  
SCULPTURE BY ELIO GARIS "ELISSE" (2007) painted acrylic resin cm. 250x120x225 H



# 3156

**TIPOLOGIA DI APERTURA**  
**OPENING SYSTEM**

SCORREVOLE WALLDOOR

**VETRO**

**GLASS**

BRONZO SATINATO INCISO

**MANIGLIONE**

**HANDLE**

CODA CROMO SATINATO

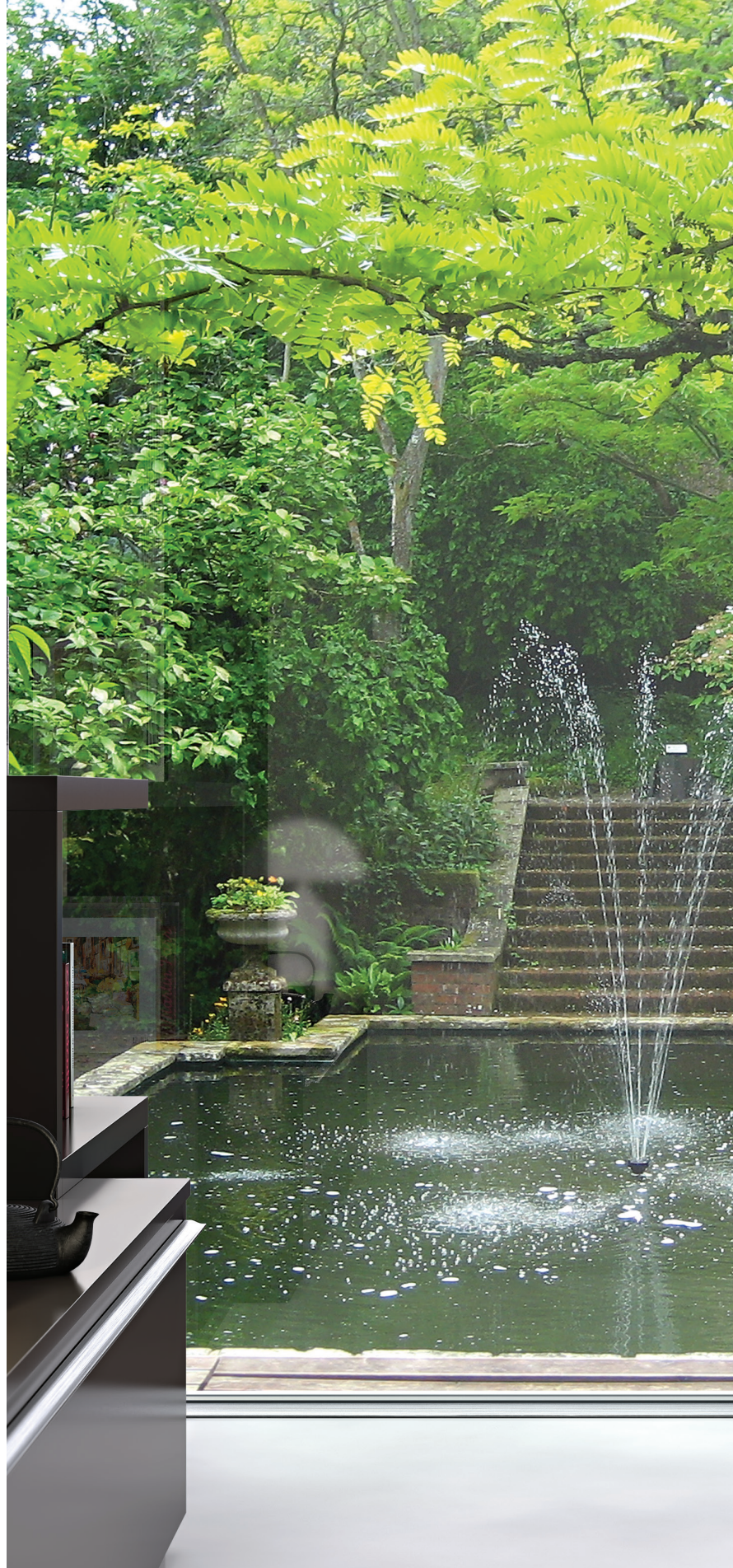











# ANDROMEDA

**TINTA**

**COLOUR**

LACCATO SABBIA

**TELAIO**

**FRAME**

T/SOR

**MANIGLIA**

**HANDLE**

BILBAO CROMO SATINATO



MODELLO ANDROMEDA







# ANDROMEDA

**TIPOLOGIA DI APERTURA**  
**OPENING SYSTEM**

BATTENTE WALLDOOR  
**TINTA**

**COLOUR**  
LACCATO BIANCO

**MANIGLIA**  
**HANDLE**  
CODA CROMO LUC./SAT.

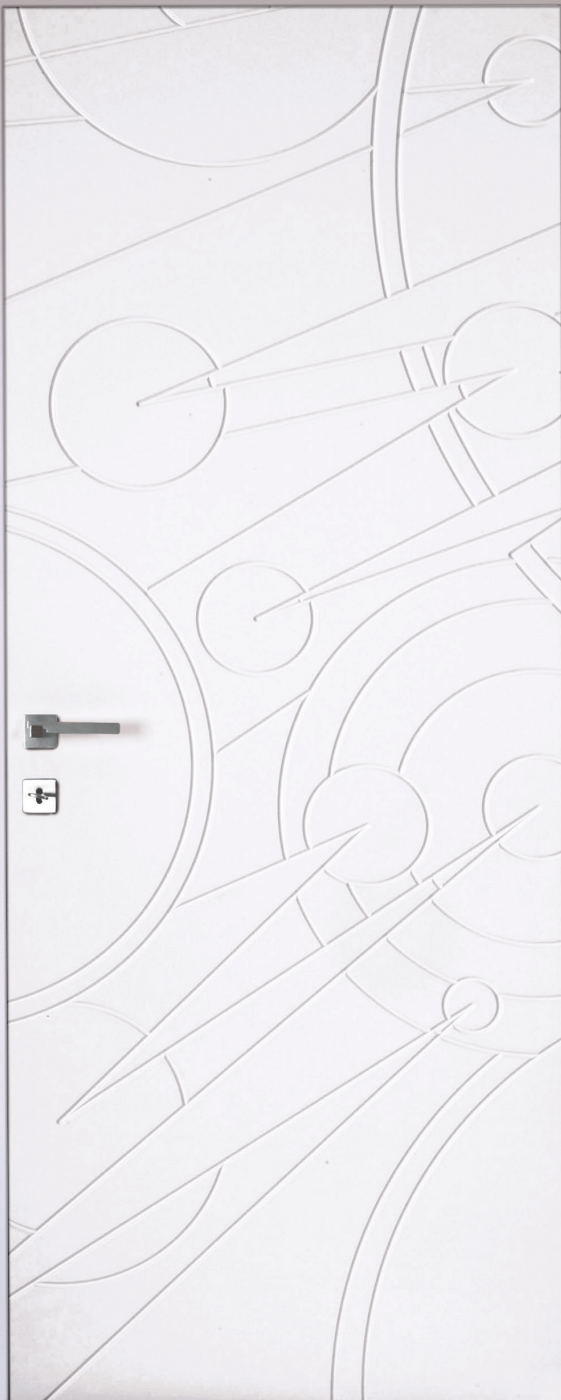



# ANDROMEDA

**TINTA**

**COLOUR**

LACCATO NCS

**TELAIO**

**FRAME**

T/SOR

**MANIGLIA**

**HANDLE**

BILBAO CROMO SATINATO









# SURPRISE

UN'ORIGINALE INTERPRETAZIONE DI MADIA CONTENITORE DAL DESIGN INNOVATIVO. IL COPERCHIO SI ELEVA RIVELANDONE L'INTERNO STUDIATO PER UN "CONTENERE" SPECIALISTICO. ESTERNAMENTE IL PRODOTTO SI PRESENTA COME UN'IMMAGINE RIGOROSA VALORIZZATA DA MOTIVI GEOMETRICI "COSTELLAZIONI", PANTOGRAFATI DIRETTAMENTE SULLA SUPERFICIE DELLA MADIA.

*AN ORIGINAL INTERPRETATION OF "MADIA" PIECE OF FURNITURE WITH AN INNOVATIVE DESIGN. THE COVER IS LIFTED UP SHOWING THE STUDIED SPECIALIZED COVER. EXTERNALLY THE PRODUCT LOOKS LIKE A PRECISE IMAGE ENRICHED WITH GEOMETRIC "COSTELLAZIONI" DESIGN COLLECTION, DIRECTLY ENGRAVED BY PANTOGRAPH ON MADIA SURFACE.*

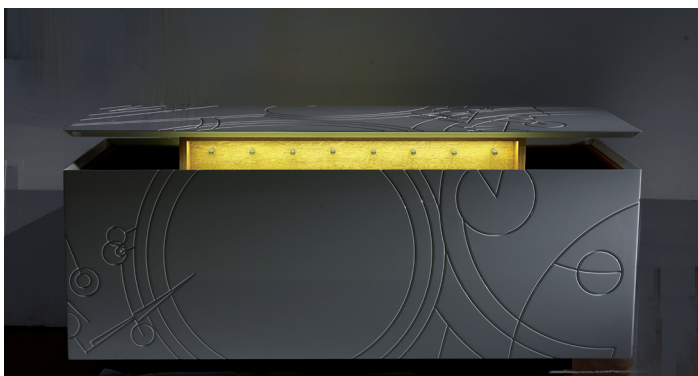
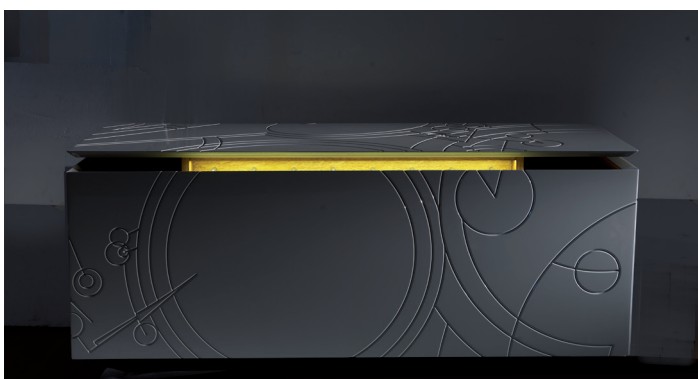



# 3152

**VETRO**

**GLASS**

SATINATO INCISO

**TELAIO**

**FRAME**

T/SOR LACCATO BIANCO

**MANIGLIA**

**HANDLE**

BILBAO CROMO SATINATO

**BATTISCOPA**

**SKIRTING BOARD**

B8 - LACCATO BIANCO



*SURPRISE, MOBILE BAR, LACCATO BIANCO  
SURPRISE, COCKTAIL CABINET, WHITE LACQUERED*







# AURIGA

**TINTA**  
**COLOUR**  
LACCATO BIANCO  
**TELAIO**  
**FRAME**  
TR/L8  
**MANIGLIA**  
**HANDLE**  
GENEVE CROMO SATINATO



MODELLO AURIGA







# AURIGA

**TINTA**

**COLOUR**

LACCATO BIANCO

**TELAIO**

**FRAME**

TR/L8

**MANIGLIA**

**HANDLE**

BILBAO CROMO SATINATO

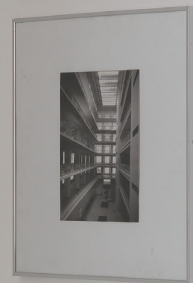
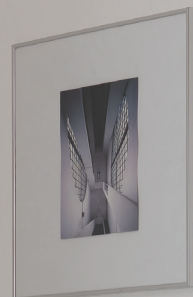



# PHANTOM





# AURIGA

**TIPOLOGIA DI APERTURA**  
**OPENING SYSTEM**  
SCORREVOLE PHANTOM

**TINTA**  
**COLOUR**  
LACCATO CIPRIA

**MANIGLIONE**  
**HANDLE**  
CODA CROMO SATINATO



SCULTURA DI ELIO GARIS "MACCHINA PER 550x450x300 H" (1995) ferro ossidato e acciaio inox  
SCULPTURE BY ELIO GARIS "MACCHINA PER 550x450x300 H" (1995) oxidised iron and stainless steel



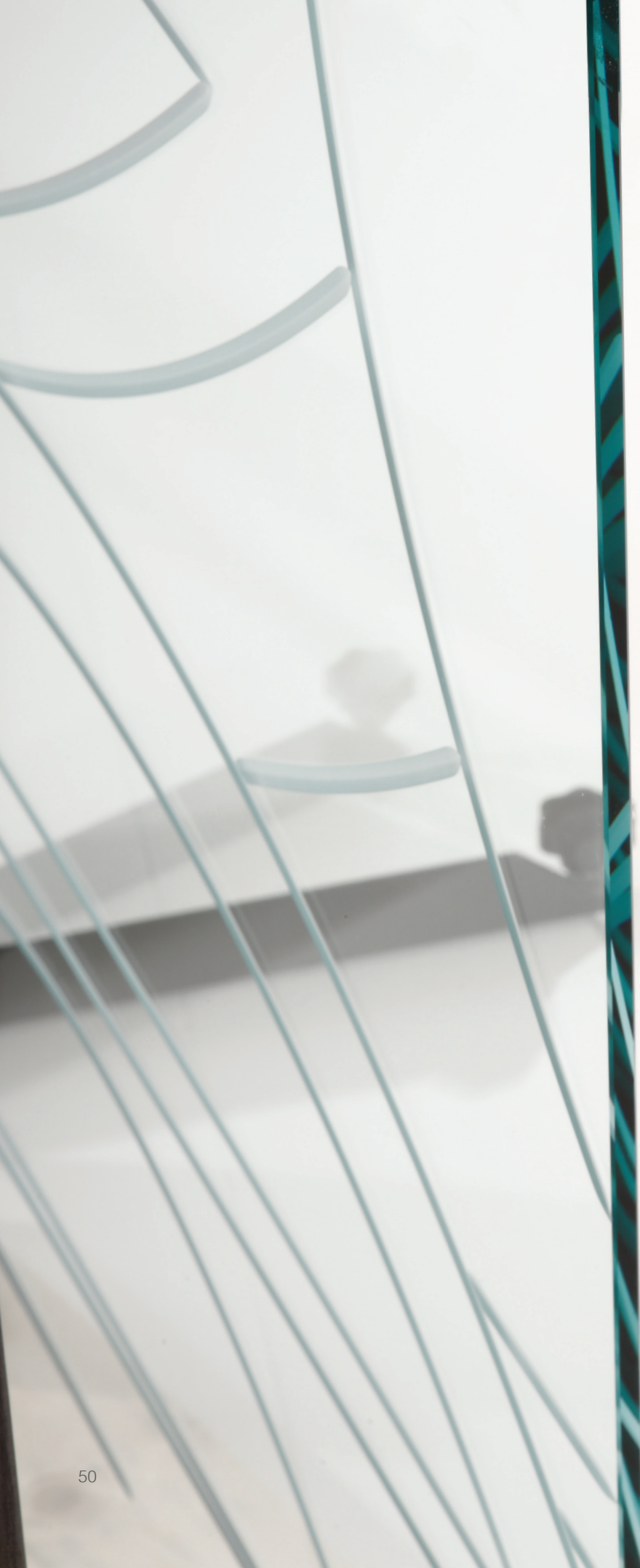





# 3153

**VETRO**

**GLASS**

TRASPARENTE INCISO

**TELAIO**

**FRAME**

TR/L8 LACCATO RAL

**MANIGLIA**

**HANDLE**

BILBAO CROMO SATINATO









# AURIGA

**TINTA**

**COLOUR**

LACCATO CIPRIA

**TELAIO**

**FRAME**

TR/L8

**MANIGLIA**

**HANDLE**

MANIGLIA PARROT CROMO LUC./SAT.

**BATTISCOPIA**

**SKIRTING BOARD**

B8 - LACCATO CIPRIA







PORTE IN LEGNO LACCATE, CON FINITURA OPACA O LUCIDA A SPECCHIO;  
SULL'ANTA A BORDO QUADRO LE INCISIONI REALIZZATE CON UTENSILI  
DI ULTIMA GENERAZIONE RIPRODUCONO DISEGNI E LINEE ISPIRATE DA  
UN DESIGN ELEGANTE E UNICO.

*WOODEN LACQUERED DOORS WITH MATT OR GLOSSY MIRROR EFFECT  
FINISH; ENGRAVINGS ON SQUARE EDGE DOOR LEAF ARE MADE WITH  
LAST GENERATION TOOLS AND THEY REPRODUCE MOTIFS AND LINES  
INSPIRED BY AN ELEGANT AND UNIQUE DESIGN.*



# CASSIOPEA

**TINTA**

**COLOUR**

LACCATO RAL

**TELAIO**

**FRAME**

TR/L8

**MANIGLIA**

**HANDLE**

BILBAO CROMO SATINATO

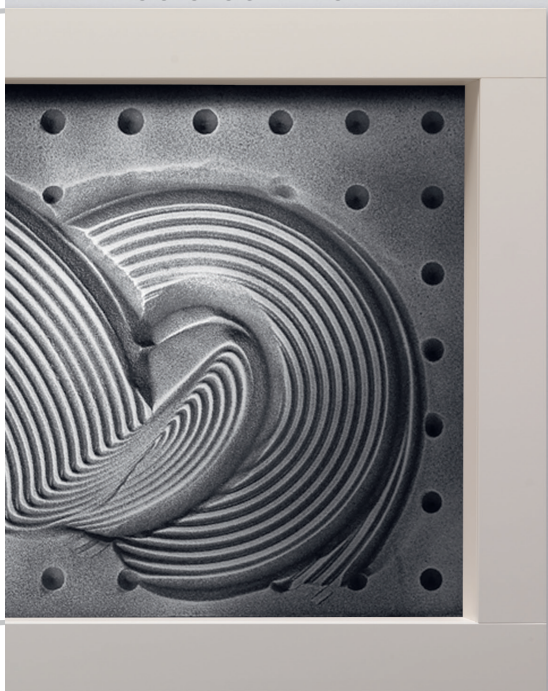

MODELLO CASSIOPEA



# CASSIOPEA

**TIPOLOGIA DI APERTURA**  
**OPENING SYSTEM**

BOISERIE INDIVIDUAL CON  
WALLDOOR

**TINTA**

**COLOUR**

LACCATO BIANCO E RAL

**MANIGLIA**

**HANDLE**

BILBAO CROMO SATINATO



**SURPRISE** MOBILE BAR,  
LACCATO BIANCO







# CASSIOPEA

**TINTA**

**COLOUR**

LACCATO BIANCO

**TELAIO**

**FRAME**

T/REV

**MANIGLIA**

**HANDLE**

BILBAO CROMO SATINATO









# BIDIREZIONALE

## APERTURA UNIVERSALE

UNIVERSAL OPENING



L'ESSENZIALITA' DI UNA PORTA UNICA CHE RACCHIUDE IN SE' TUTTI I SISTEMI DI APERTURA: CON LA BIDIREZIONALE BERTOLOTTO E' POSSIBILE OTTENERE QUALUNQUE TIPO DI SPINTA, ORDINANDO SEMPLICEMENTE UN UNICO PRODOTTO.

RUOTANDO L'INTERA PORTA SI PUO' INFATTI OTTENERE LA SPINTA DESTRA, TIRA DESTRA, SPINTA SINISTRA E TIRA SINISTRA.

INOLTRE CON QUESTO SISTEMA SI HA LA POSSIBILITA' DI APRIRE L'ANTA TIRANDOLA O SPINGENDOLA.

FORNITA DI SERIE CON SERRATURA MAGNETICA E CERNIERE A BILICO E' DISPONIBILE CON 2 TIPOLOGIE DI TELAI, PA (STANDARD SU TUTTI I LACCATI) E PR (A RICHIESTA), PER CONSENTIRE UN ABBINAMENTO OTTIMALE CON GLI ALTRI PRODOTTI DELLA NOSTRA GAMMA.

DISPONIBILE IN TUTTI I COLORI LACCATI BP, RAL E NCS.

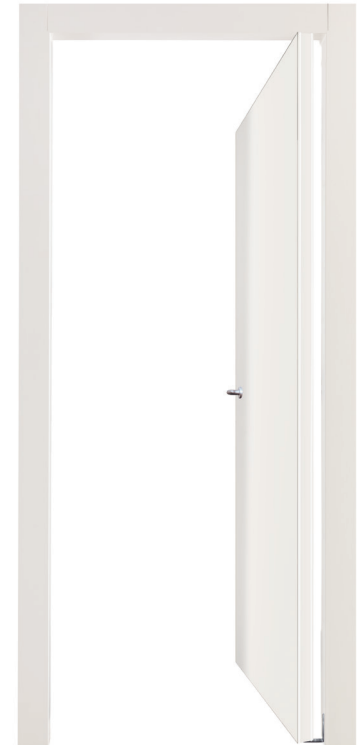

*A UNIQUE AND ESSENTIAL DOOR THAT INCLUDE ALL OPENING SYSTEMS, WITH BERTOLOTTO BIDIREZIONALE IT IS POSSIBLE TO OBTAIN*

*EACH KIND OF OPENING DIRECTION, BY ORDERING SIMPLY ONE PRODUCT.*

*BY ROTATING THE FULL DOOR YOU CAN OBTAIN PUSH RIGHT, PULL RIGHT, PUSH LEFT AND PULL LEFT. MOREOVER, WITH THIS SYSTEM IT IS POSSIBLE TO OPEN THE DOOR PUSHING OR PULLING THE LEAF.*

*EQUIPPED WITH MAGNETIC LOCK AND PIVOT HINGES IT IS AVAILABLE WITH 2 FRAME TYPOLOGIES: PA (STANDARD ON ALL FINISHING)*

*AND PR (ON REQUEST FOR LACQUERING AND WOOD FINISHES), TO ALLOW A PERFECT MATCHING WITH OUR PRODUCT RANGE.*

*AVAILABLE IN ALL LACQUERED COLOURS BP, RAL AND NCS, AND IN ALLE LAMINATED FINISHES.*

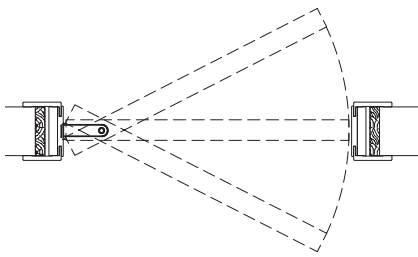

SPINTA SINISTRA/TIRA SINISTRA  
PUSH LEFT/PULL LEFT

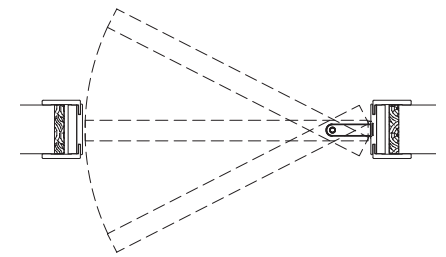

SPINTA DESTRA/TIRA DESTRA  
PUSH RIGHT/PULL RIGHT



# CASSIOPEA

**TIPOLOGIA DI APERTURA**

**OPENING SYSTEM**

BIDIREZIONALE

**TINTA**

**COLOUR**

LACCATO BIANCO

**TELAIO**

**FRAME**

PASSATA PA

**MANIGLIA**

**HANDLE**

BILBAO CROMO SATINATO

**BATTISCOPIA**

**SKIRTING BOARD**

B8 - LACCATO BIANCO





# SERRATURA MAGNETICA E CERNIERE A SCOMPARSA









# INDIVIDUAL

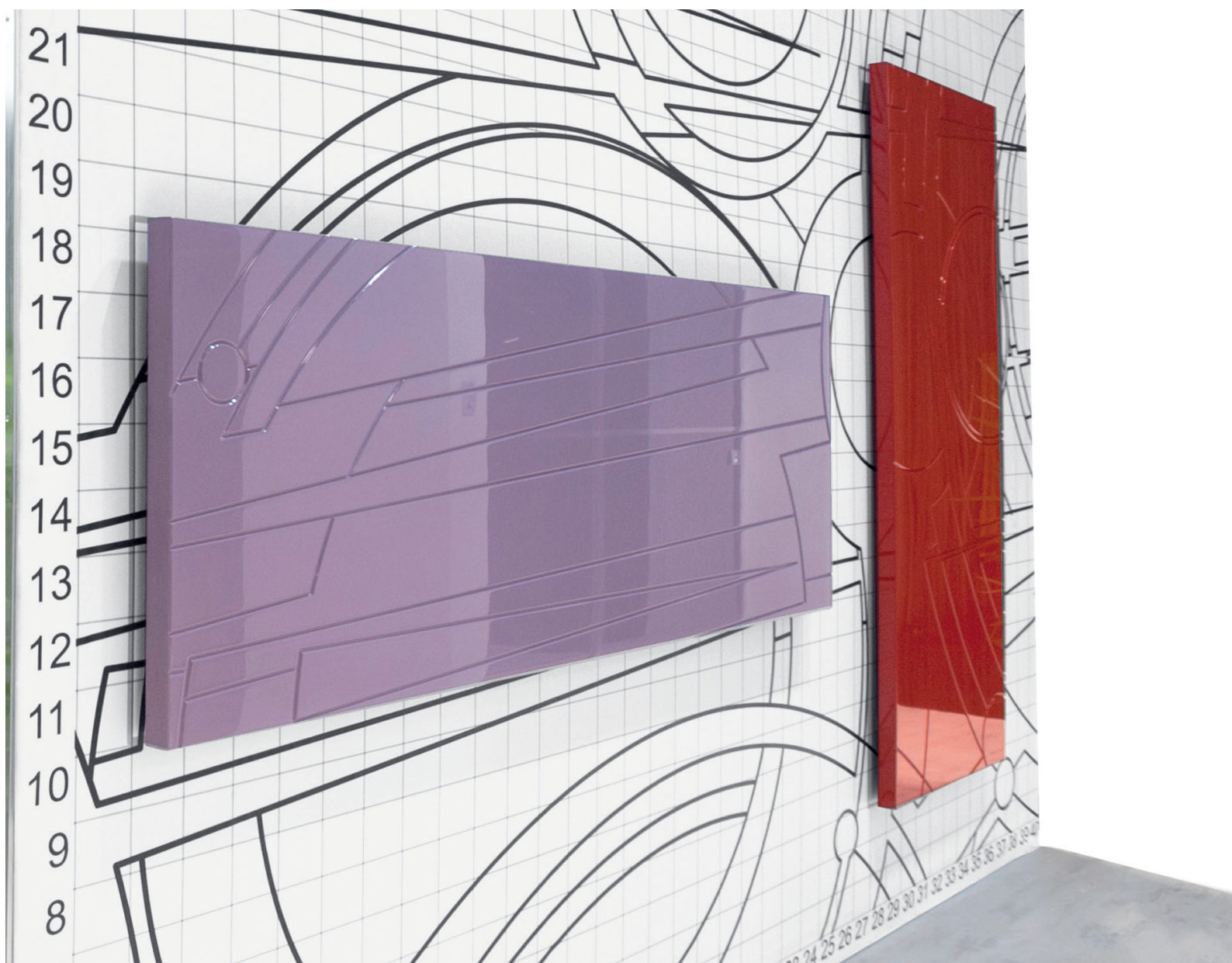

Per creare un ambiente "unico" scegli aiutandoti con la dima in cartoncino, quale porzione della costellazione meglio rappresenta la tua individualità. Bertolotto la riprodurrà su porte o pareti scorrevoli, con pannelli modulabili fino a dimensioni massime di 290 cm x 90 cm. Tutti i modelli vengono realizzati su misura, solo per TE.

*To create an unique space, you can choose, with the help of the card board template, which part of Costellazioni best represents your personality. Bertolotto will reproduce it on hinged or sliding doors with modular panels, up to maximum dimensions of 290 x 90 cm. All models are custom-made just for YOU.*



# ARMADIO VEGA

INDIVIDUAL

**TINTA**

**COLOUR**

LACCATO BIANCO

**POMOLO**

**KNOB**

A SCOMPARSA SPINGI/TIRA

TONDO





# PORTE BLINDATE

REINFORCED DOORS



LE PORTE BLINDATE SONO DOTATE DI DOPPIA CERNIERA REGISTRABILE SUI TRE ASSI CON PRECISIONE MICROMETRICA. PER COMPLETARE IL SISTEMA I CAPPUCCI IN TINTA ABBINATI AI QUATTRO COLORI DEL TELAIO.

*OUR REINFORCED DOORS ARE PROVIDED WITH DOUBLE ADJUSTABLE 3 AXES HINGES WITH MICROMETRIC PRECISION. THE UNIT IS COMPLETED WITH COVERS MATCHING THE FOUR FRAME COLOURS.*

SECUR





# PEGASO

## SECUR

PORTA BLINDATA

*SECURITY DOOR*

## TINTA

### COLOUR

LACCATO ROSSO

### TELAIO E CARTER ANTA

**FRAME AND CARTER LEAF**

FINITURA SILVER

### MANIGLIERIA

#### HANDLE

CROMO SATINATO





# VEGA

## SECUR

PORTA BLINDATA  
*SECURITY DOOR*

## TINTA

### COLOUR

LACCATO SABBIA

### TELAIO E CARTER ANTA

FRAME AND CARTER LEAF

FINITURA NERO

### MANIGLIERIA

### HANDLE

CROMO SATINATO

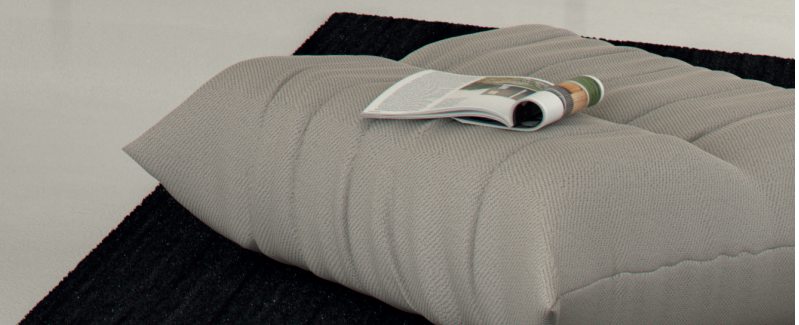



# ALTAIR

## SECUR

PORTA BLINDATA  
SECURITY DOOR

## TINTA

### COLOUR

LACCATO QUARZO

## TELAIO E CARTER ANTA

FRAME AND CARTER LEAF

FINITURA NERO

## MANIGLIERIA

### HANDLES

CROMO SATINATO





# COSTELLAZIONI BOISERIE

NUOVE CONFORMAZIONI DI SPAZI ELEGANTI E CONTEMPORANEI, CREATI DALLE BOISERIE COSTELLAZIONI.

OGNI DECORO È REALIZZABILE, OGNI AMBIENTE È PERSONALIZZABILE. CON STILE.

*NEW CREATIONS OF ELEGANT AND CONTEMPORARY SPACES ARE CREATED BY COSTELLAZIONI WALL PANELINGS.*

*EVERY DECOR CREATION CAN BE MADE AND EVERY SPACE CAN BE CUSTOMIZED WITH STYLE.*



INTERE PARETI O STANZE POSSONO DIVENTARE AMBIENTI "COSTELLAZIONI".

LA BOISERIE NASCE PER CREARE UN INSIEME ARMONIOSO TRA LA PORTA, L'ARMADIO, LA NICCHIA, LA PARETE: UN SISTEMA SEMPLICE CHE NON RICHIEDE INTERVENTI STRUTTURALI IN CASA TUA.

SCEGLI IL DECORO, FORNISCI LE DIMENSIONI E NOI REALizzerEMO IL PROGETTO PER LA TUA PARETE.

*WALLS OR ROOMS CAN BECOME "COSTELLAZIONI" SPACES.*

*WALL PANELING HAS BEEN CREATED IN ORDER TO HAVE AN HARMONIOUS WHOLE AMONG THE DOOR, THE WARDROBE, THE NICHE AND THE WALL: AN EASY SYSTEM THAT DOESN'T NEED STRUCTURAL INTERVENTIONS YOUR HOUSE.*

*YOU CHOOSE THE DECORATION AND PROVIDE THE DIMENSIONS, AND WE WILL CREATE THE PROJECT FOR YOUR WALL.*

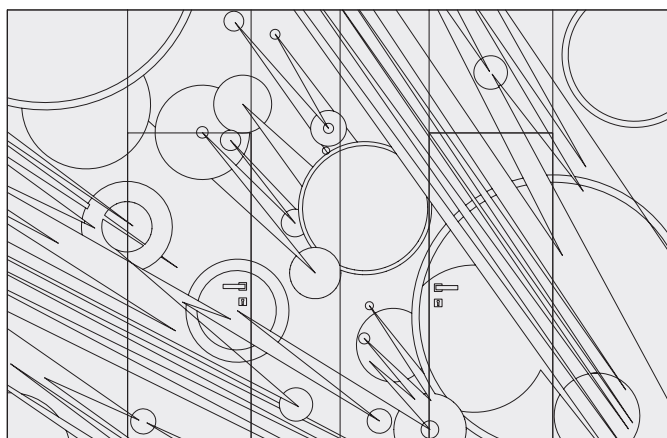

L'UFFICIO TECNICO BERTOLOTTO PORTE È A DISPOSIZIONE PER LA REALIZZAZIONE DI PROGETTI PERSONALIZZATI PER LE BOISERIE E RIVESTIMENTI PARETI.

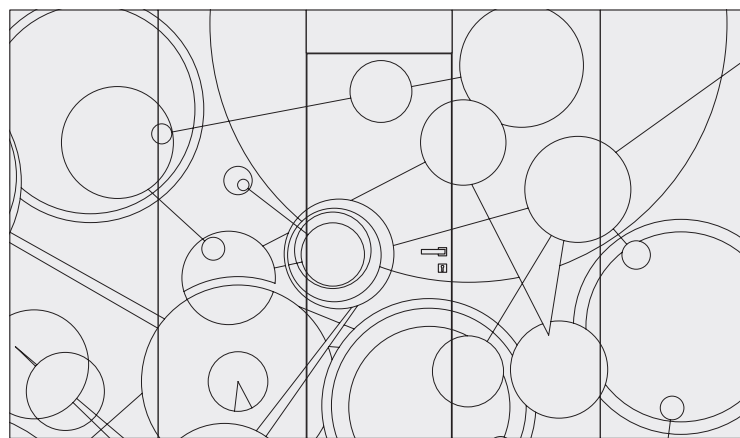

*BERTOLOTTO PORTE TECHNICAL DEPARTMENT IS AVAILABLE TO CREATE CUSTOMIZED PROJECTS FOR PANELING AND WALL COVERINGS.*



# ESEMPI QUADRI COSTELLAZIONI

LINEE SINUOSE E DECORI COSTELLAZIONI ANCHE PER LE PARETI: IL QUADRO, LACCATO NEI COLORI BERTOLOTTO, RAL E NCS, CON FINITURA OPACA O LUCIDA. UNA NOVITÀ PER ARREDARE LA CASA.

*COSTELLAZIONI CURVY LINES AND DECORATIONS COLLECTION ALSO FOR THE WALLS: DOOR "PICTURE" IS LACQUERED WITH BERTOLOTTO, RAL AND NCS COLORS WITH MATT OR GLOSSY FINISH. THE A NEWS TO FURNISH YOUR HOME.*



**VEGA** QUADRO CON CORNICE

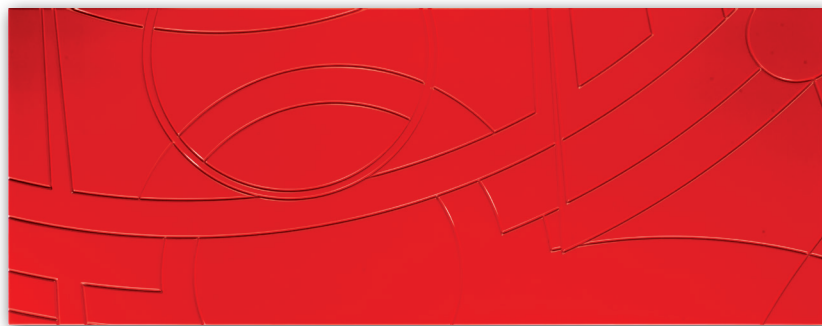

**VEGA** QUADRO SENZA CORNICE



# PEGASO INDIVIDUAL

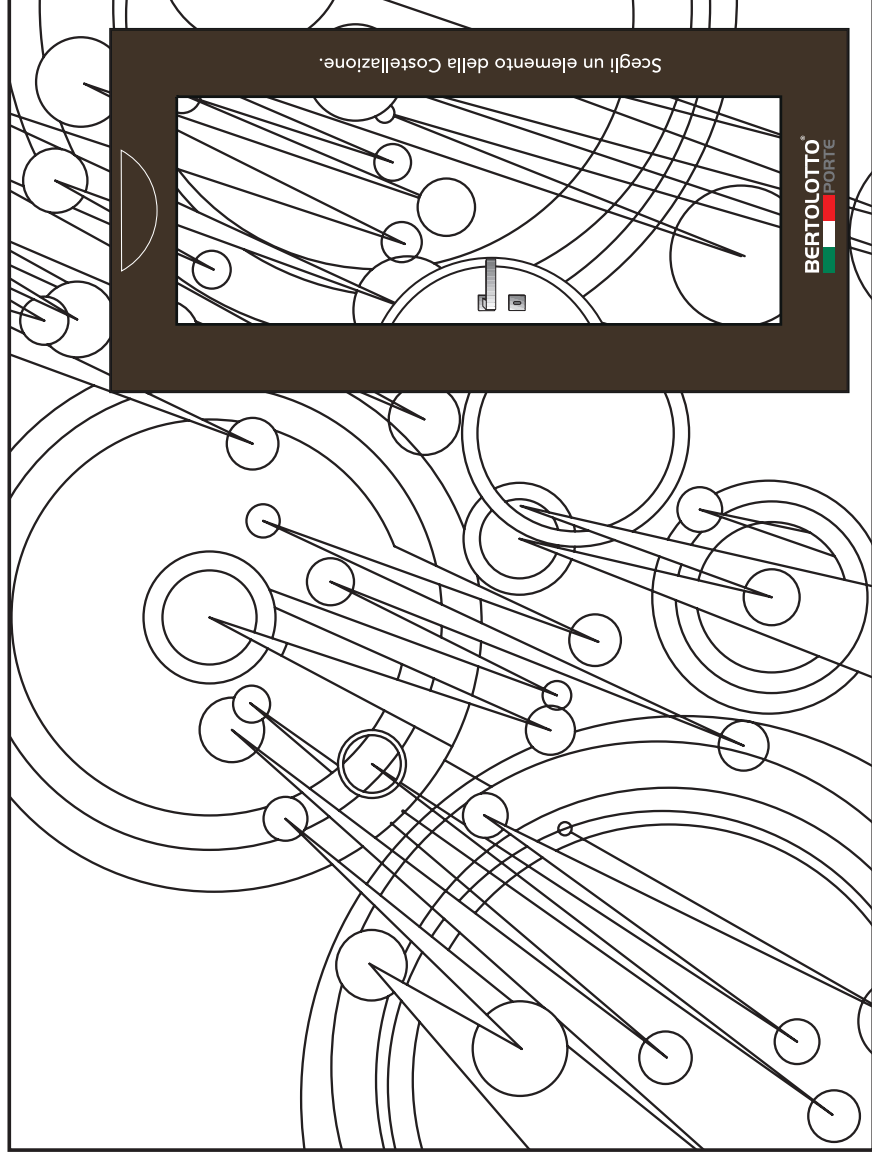

PER CREARE UN AMBIENTE "UNICO" SCEGLI, AIUTANDOTI CON LA DIMA IN CARTONCINO, QUALE PORZIONE DELLA COSTELLAZIONE MEGLIO RAPPRESENTA LA TUA INDIVIDUALITÀ. BERTOLOTTO LA RIPRODurrÀ SU PORTE O PARETI SCORREVOLI, CON PANNELLI MODULABILI FINO A DIMENSIONI MASSIME DI 290 X 90 CM. TUTTI I MODELLI VENGONO REALIZZATI SU MISURA, COME UN ABITO, SOLO PER TE. LA DIMA HA LO STESSO RAPPORTO, IN SCALA RIDOTTA, DELLE DIMENSIONI DI UNA PORTA STANDARD 210 X 80 CM.

TO CREATE AN UNIQUE SPACE, YOU CAN CHOOSE, WITH THE HELP OF THE CARD BOARD TEMPLATE, WHICH PART OF COSTELLAZIONI BEST REPRESENTS YOUR PERSONALITY. BERTOLOTTO WILL REPRODUCE IT ON HINGED OR SLIDING DOORS WITH MODULAR PANELS, UP TO MAXIMUM DIMENSIONS OF 290 X 90 CM. ALL MODELS ARE CUSTOM-MADE JUST FOR YOU. THE TEMPLATE HAS THE SAME RATIO, ON A SMALL SCALE, OF STANDARD DOOR DIMENSION (210 X 80 CM).



Y

30

29

28

27

26

25

24

23

22

21

20

19

18

17

16

15

14

13

12

11

10

9

8

7

6

5

4

3

2

1

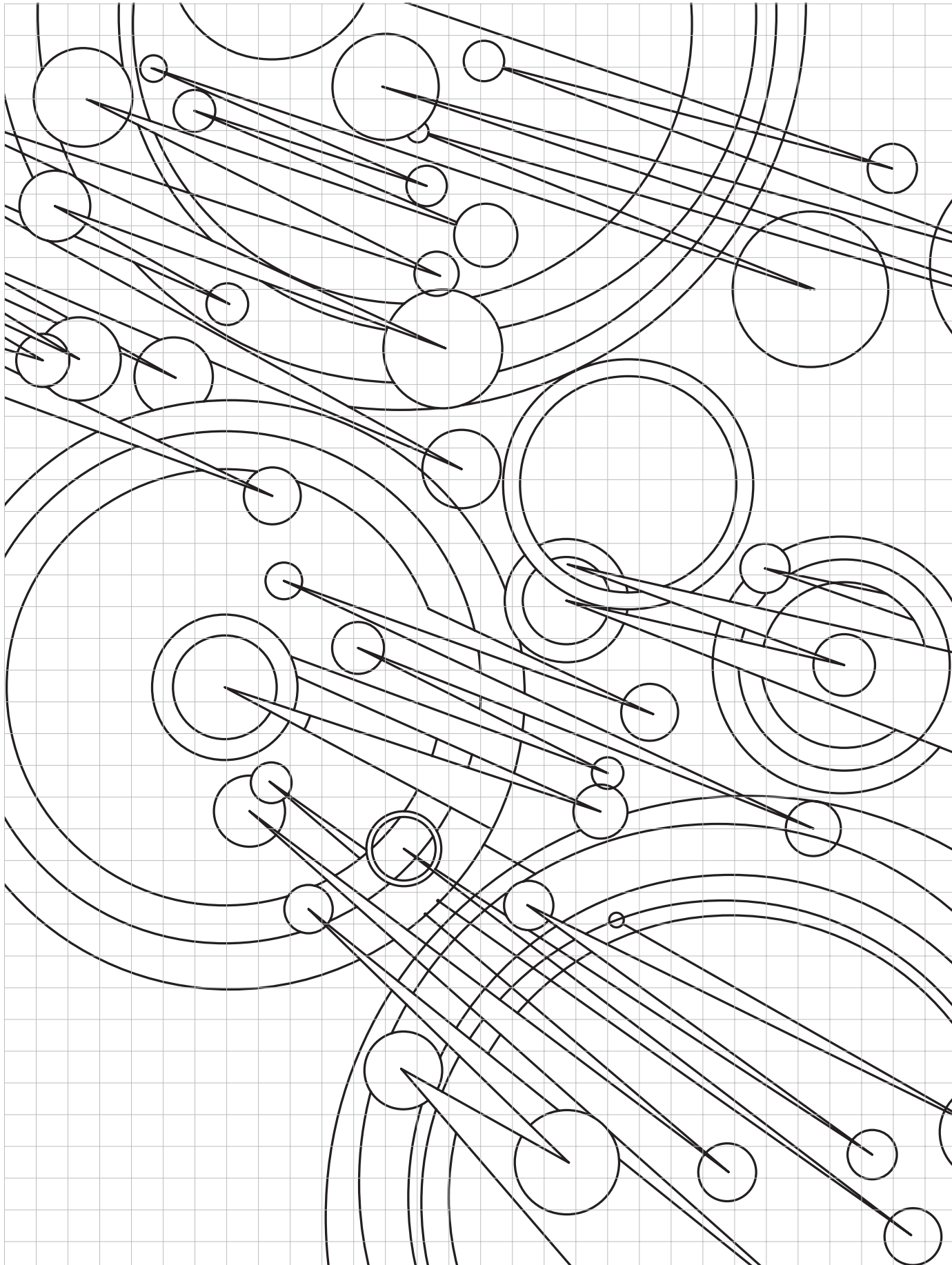

X

1 2 3 4 5 6 7 8 9 10 11 12 13 14 15 16 17 18 19 20 21 22 23 24 25 26 27 28 29 30 31 32 33 34 35 36 37 38 39 40

SCEGLI LA PORZIONE DELLA COSTELLAZIONE CHE PREFERISCI  
CHOOSE WHICH PART OF COSTELLAZIONI YOU PREFER

## ALTAIR INDIVIDUAL



PER CREARE UN AMBIENTE "UNICO" SCEGLI, AIUTANDOTI CON LA DIMA IN CARTONCINO, QUALE PORZIONE DELLA COSTELLAZIONE MEGLIO RAPPRESENTA LA TUA INDIVIDUALITÀ. BERTOLOTTO LA RIPRODurrÀ SU PORTE O PARETI SCORREVOLI, CON PANNELLI MODULABILI FINO A DIMENSIONI MASSIME DI 290 X 90 CM. TUTTI I MODELLI VENGONO REALIZZATI SU MISURA, COME UN ABITO, SOLO PER TE. LA DIMA HA LO STESSO RAPPORTO, IN SCALA RIDOTTA, DELLE DIMENSIONI DI UNA PORTA STANDARD 210 X 80 CM.

TO CREATE AN UNIQUE SPACE, YOU CAN CHOOSE, WITH THE HELP OF THE CARD BOARD TEMPLATE, WHICH PART OF COSTELLAZIONI BEST REPRESENTS YOUR PERSONALITY. BERTOLOTTO WILL REPRODUCE IT ON HINGED OR SLIDING DOORS WITH MODULAR PANELS, UP TO MAXIMUM DIMENSIONS OF 290 X 90 CM. ALL MODELS ARE CUSTOM-MADE JUST FOR YOU. THE TEMPLATE HAS THE SAME RATIO, ON A SMALL SCALE, OF STANDARD DOOR DIMENSION (210 X 80 CM).



Y

30

29

28

27

26

25

24

23

22

21

20

19

18

17

16

15

14

13

12

11

10

9

8

7

6

5

4

3

2

1

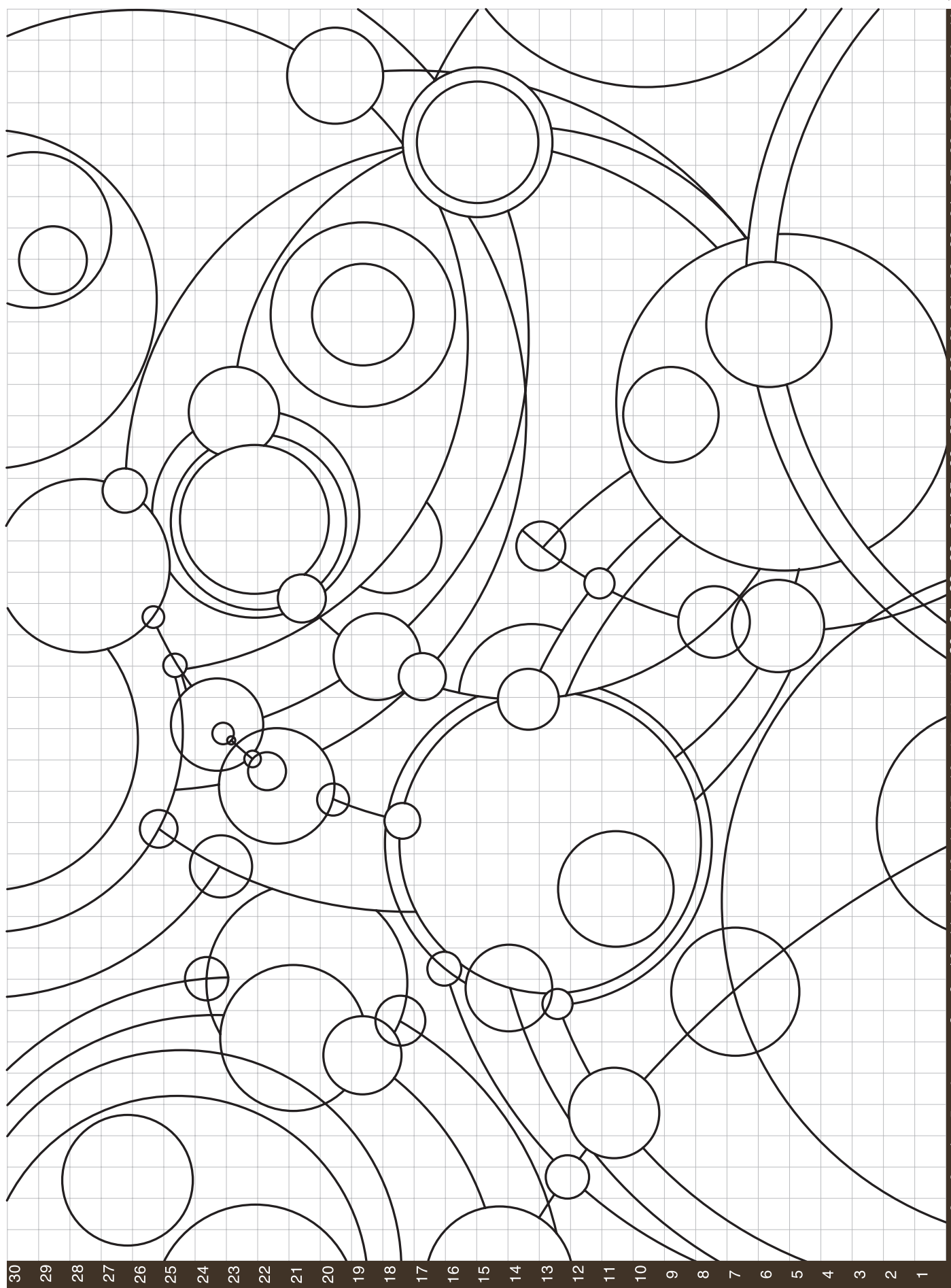

1 2 3 4 5 6 7 8 9 10 11 12 13 14 15 16 17 18 19 20 21 22 23 24 25 26 27 28 29 30 31 32 33 34 35 36 37 38 39 40 X

SCEGLI LA PORZIONE DELLA COSTELLAZIONE CHE PREFERISCI  
CHOOSE WHICH PART OF COSTELLAZIONI YOU PREFER

# VEGA INDIVIDUAL

76

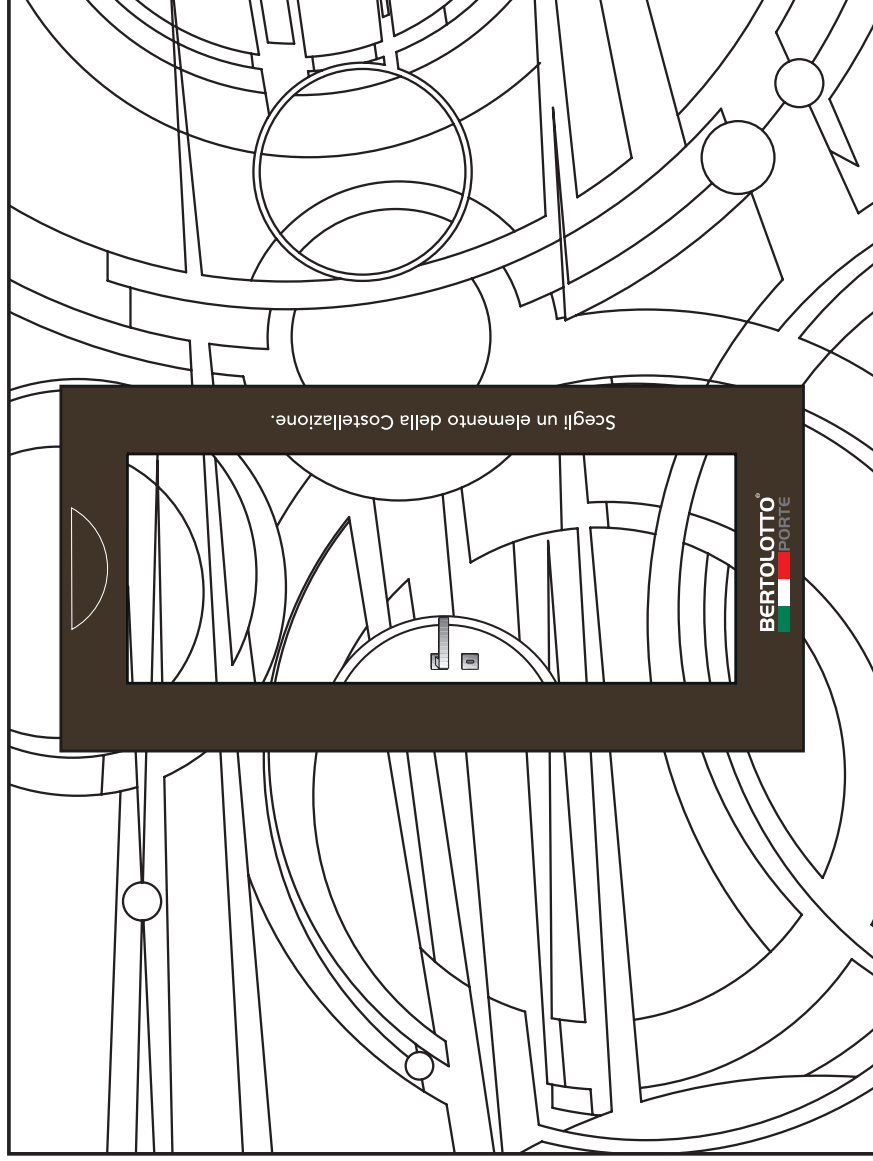

PER CREARE UN AMBIENTE "UNICO" SCEGLI, AIUTANDOTI CON LA DIMA IN CARTONCINO, QUALE PORZIONE DELLA COSTELLAZIONE MEGLIO RAPPRESENTA LA TUA INDIVIDUALITÀ. BERTOLOTTO LA RIPRODurrÀ SU PORTE O PARETI SCORREVOLI, CON PANNELLI MODULABILI FINO A DIMENSIONI MASSIME DI 290 X 90 CM. TUTTI I MODELLI VENGONO REALIZZATI SU MISURA, COME UN ABITO, SOLO PER TE. LA DIMA HA LO STESSO RAPPORTO, IN SCALA RIDOTTA, DELLE DIMENSIONI DI UNA PORTA STANDARD 210 X 80 CM.

TO CREATE AN UNIQUE SPACE, YOU CAN CHOOSE, WITH THE HELP OF THE CARD BOARD TEMPLATE, WHICH PART OF COSTELLAZIONI BEST REPRESENTS YOUR PERSONALITY. BERTOLOTTO WILL REPRODUCE IT ON HINGED OR SLIDING DOORS WITH MODULAR PANELS, UP TO MAXIMUM DIMENSIONS OF 290 X 90 CM. ALL MODELS ARE CUSTOM-MADE JUST FOR YOU. THE TEMPLATE HAS THE SAME RATIO, ON A SMALL SCALE, OF STANDARD DOOR DIMENSION (210 X 80 CM).



Y

30

29

28

27

26

25

24

23

22

21

20

19

18

17

16

15

14

13

12

11

10

9

8

7

6

5

4

3

2

1

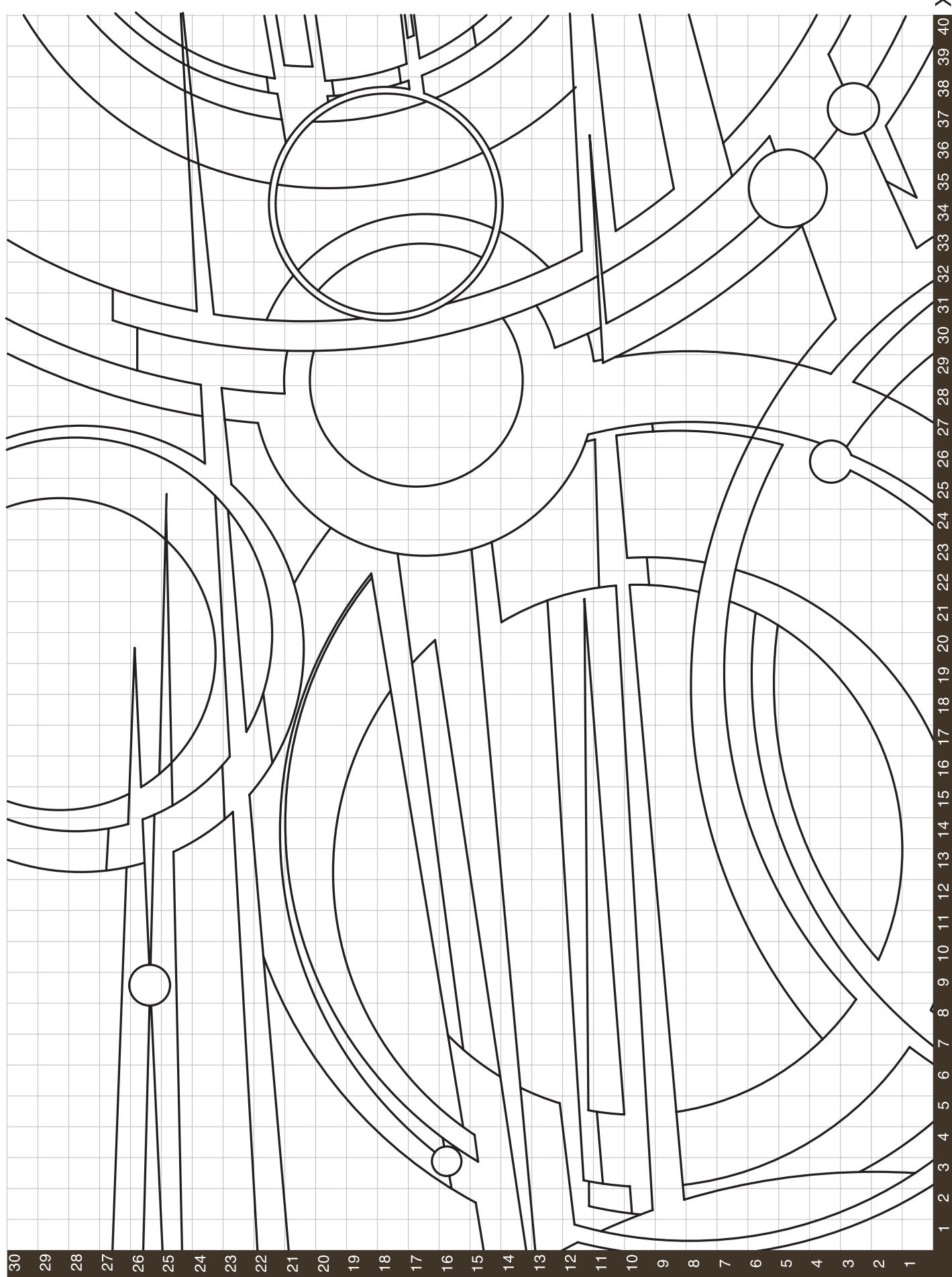

1 2 3 4 5 6 7 8 9 10 11 12 13 14 15 16 17 18 19 20 21 22 23 24 25 26 27 28 29 30 31 32 33 34 35 36 37 38 39 40 X

SCEGLI LA PORZIONE DELLA COSTELLAZIONE CHE PREFERISCI  
CHOOSE WHICH PART OF COSTELLAZIONI YOU PREFER

# ANDROMEDA INDIVIDUAL

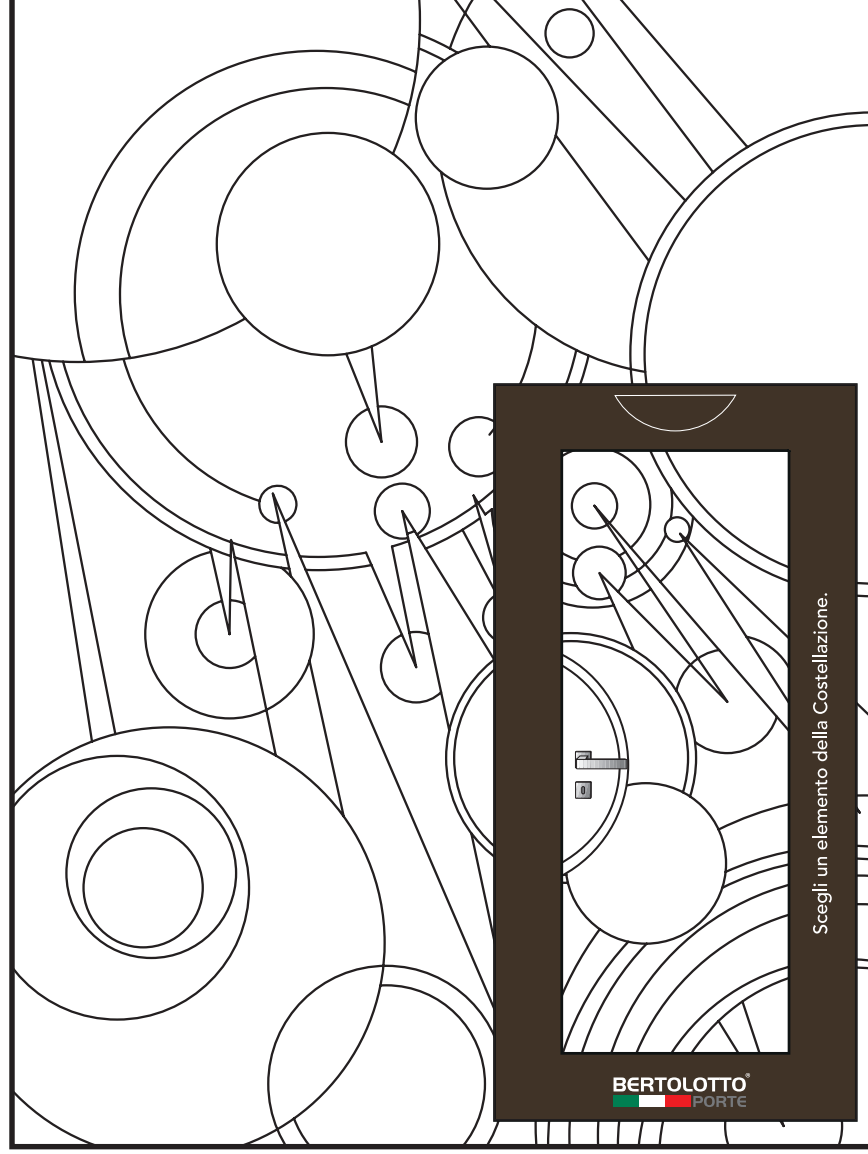

PER CREARE UN AMBIENTE "UNICO" SCEGLI, AIUTANDOTI CON LA DIMA IN CARTONCINO, QUALE PORZIONE DELLA COSTELLAZIONE MEGLIO RAPPRESENTA LA TUA INDIVIDUALITÀ. BERTOLOTTO LA RIPRODurrà SU PORTE O PARETI SCORREVOLI, CON PANNELLI MODULABILI FINO A DIMENSIONI MASSIME DI 290 X 90 CM. TUTTI I MODELLI VENGONO REALIZZATI SU MISURA, COME UN ABITO, SOLO PER TE. LA DIMA HA LO STESSO RAPPORTO, IN SCALA RIDOTTA, DELLE DIMENSIONI DI UNA PORTA STANDARD 210 X 80 CM.

TO CREATE AN UNIQUE SPACE, YOU CAN CHOOSE, WITH THE HELP OF THE CARD BOARD TEMPLATE, WHICH PART OF COSTELLAZIONI BEST REPRESENTS YOUR PERSONALITY. BERTOLOTTO WILL REPRODUCE IT ON HINGED OR SLIDING DOORS WITH MODULAR PANELS, UP TO MAXIMUM DIMENSIONS OF 290 X 90 CM. ALL MODELS ARE CUSTOM-MADE JUST FOR YOU. THE TEMPLATE HAS THE SAME RATIO, ON A SMALL SCALE, OF STANDARD DOOR DIMENSION (210 X 80 CM).



Y

30

29

28

27

26

25

24

23

22

21

20

19

18

17

16

15

14

13

12

11

10

9

8

7

6

5

4

3

2

1

1

2

3

4

5

6

7

8

9

10

11

12

13

14

15

16

17

18

19

20

21

22

23

24

25

26

27

28

29

30

31

32

33

34

35

36

37

38

39

40

X

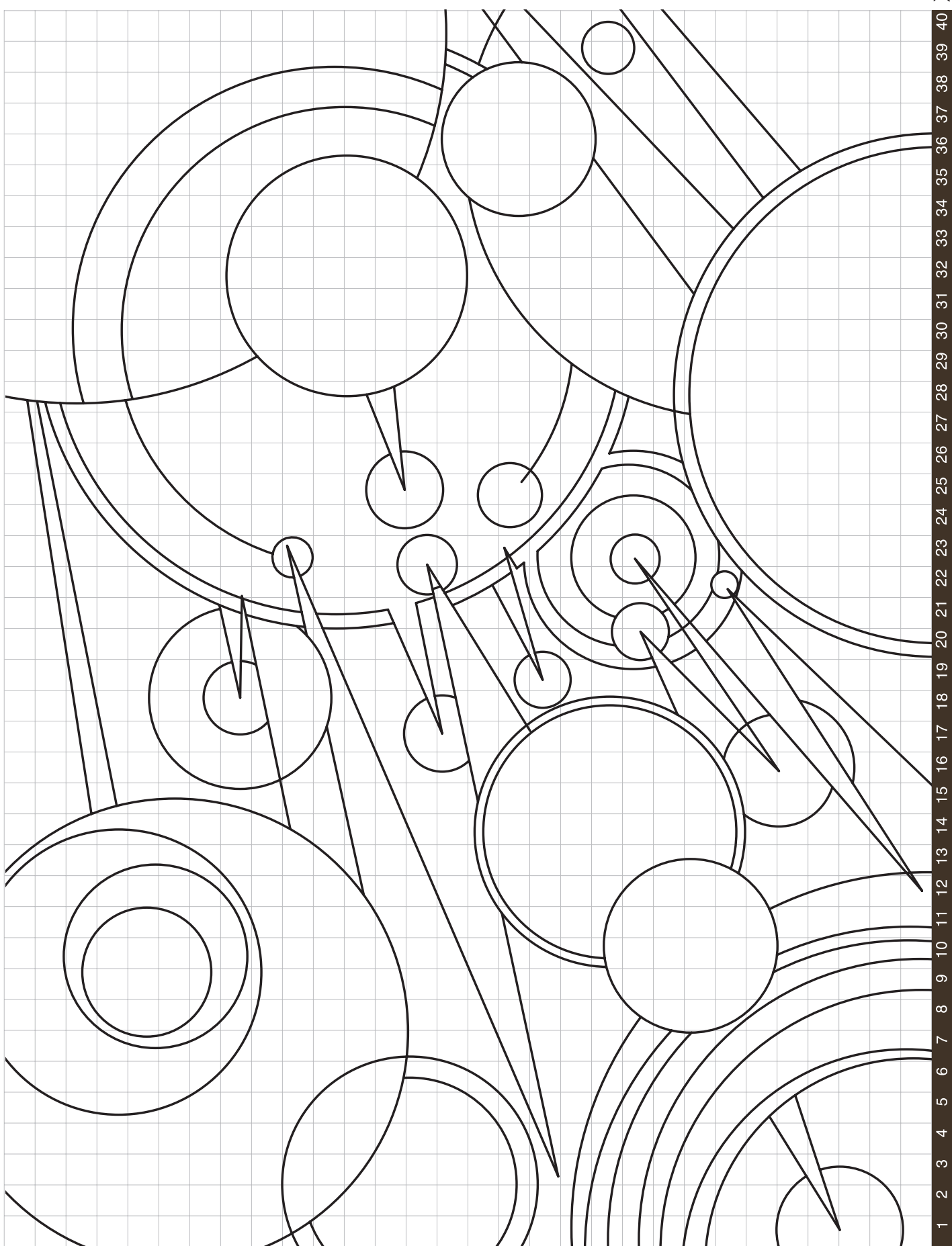

SCEGLI LA PORZIONE DELLA COSTELLAZIONE CHE PREFERISCI  
CHOOSE WHICH PART OF COSTELLAZIONI YOU PREFER

# AURIGA INDIVIDUAL

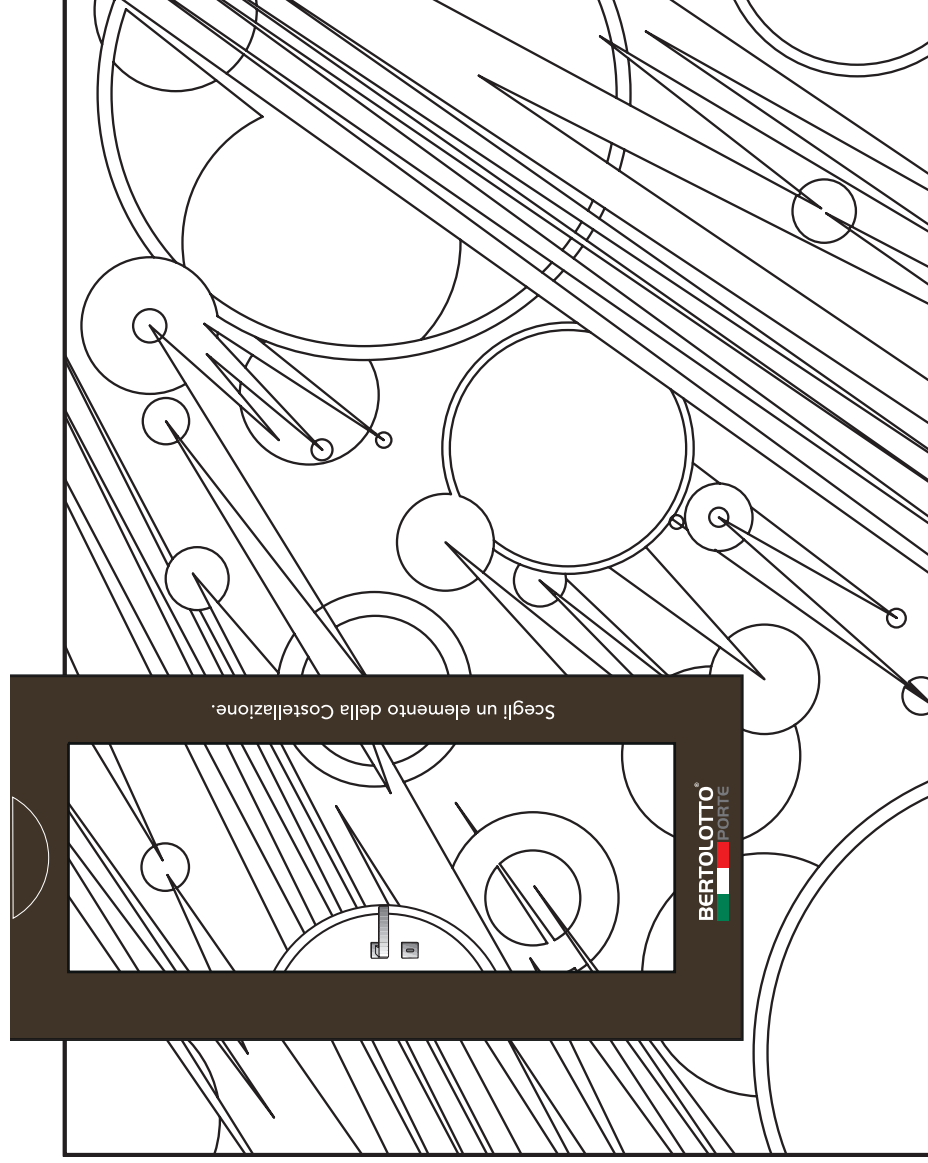

PER CREARE UN AMBIENTE "UNICO" SCEGLI, AIUTANDOTI CON LA DIMA IN CARTONCINO, QUALE PORZIONE DELLA COSTELLAZIONE MEGLIO RAPPRESENTA LA TUA INDIVIDUALITÀ. BERTOLOTTO LA RIPRODurrà SU PORTE O PARETI SCORREVOLI, CON PANNELLI MODULABILI FINO A DIMENSIONI MASSIME DI 290 X 90 CM. TUTTI I MODELLI VENGONO REALIZZATI SU MISURA, COME UN ABITO, SOLO PER TE. LA DIMA HA LO STESSO RAPPORTO, IN SCALA RIDOTTA, DELLE DIMENSIONI DI UNA PORTA STANDARD 210 X 80 CM.

TO CREATE AN UNIQUE SPACE, YOU CAN CHOOSE, WITH THE HELP OF THE CARD BOARD TEMPLATE, WHICH PART OF COSTELLAZIONI BEST REPRESENTS YOUR PERSONALITY. BERTOLOTTO WILL REPRODUCE IT ON HINGED OR SLIDING DOORS WITH MODULAR PANELS, UP TO MAXIMUM DIMENSIONS OF 290 X 90 CM. ALL MODELS ARE CUSTOM-MADE JUST FOR YOU. THE TEMPLATE HAS THE SAME RATIO, ON A SMALL SCALE, OF STANDARD DOOR DIMENSION (210 X 80 CM).



Y

30

29

28

27

26

25

24

23

22

21

20

19

18

17

16

15

14

13

12

11

10

9

8

7

6

5

4

3

2

1

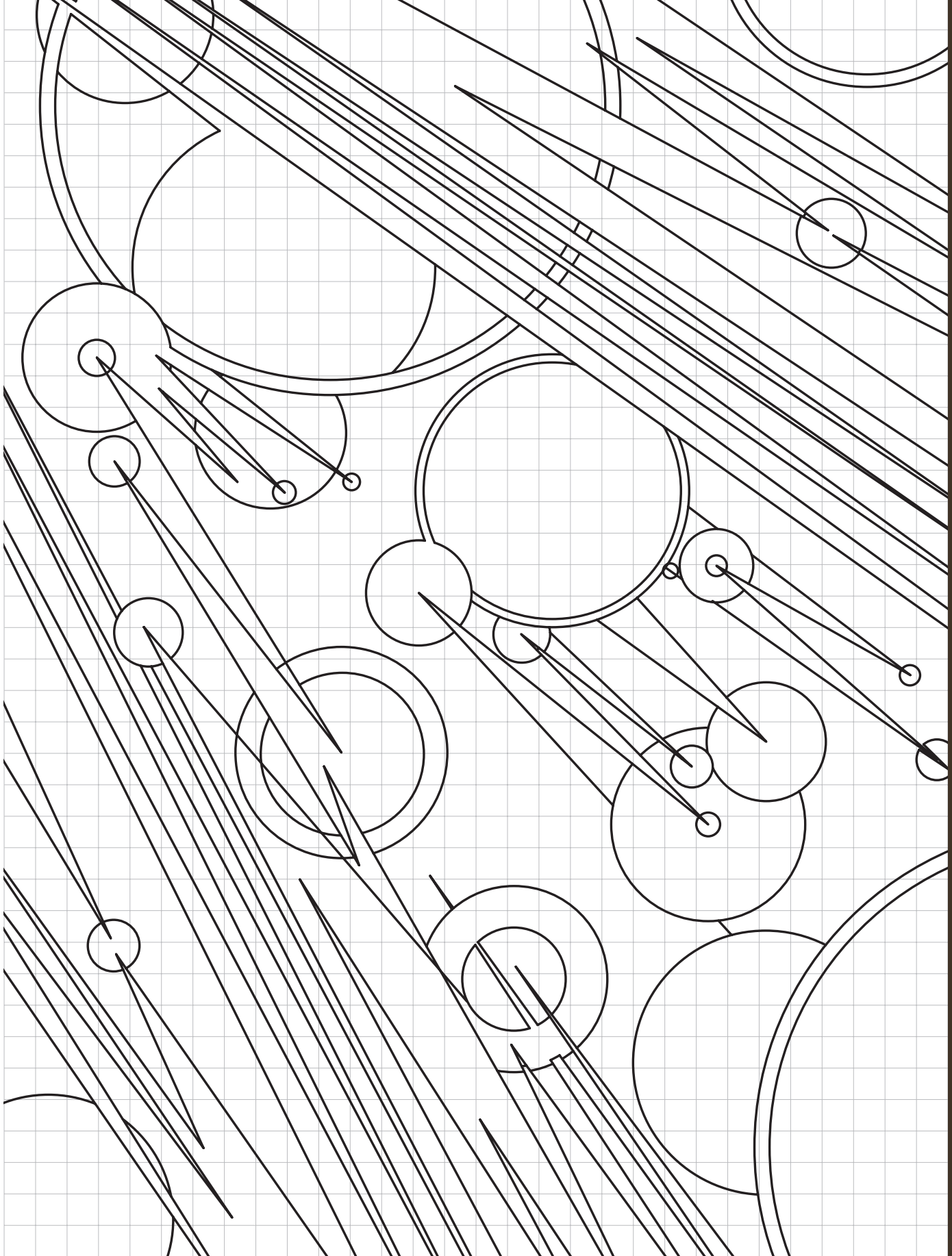

1 2 3 4 5 6 7 8 9 10 11 12 13 14 15 16 17 18 19 20 21 22 23 24 25 26 27 28 29 30 31 32 33 34 35 36 37 38 39 40

X

SCEGLI LA PORZIONE DELLA COSTELLAZIONE CHE PREFERISCI

CHOOSE WHICH PART OF COSTELLAZIONI YOU PREFER

# CASSIOPEA INDIVIDUAL

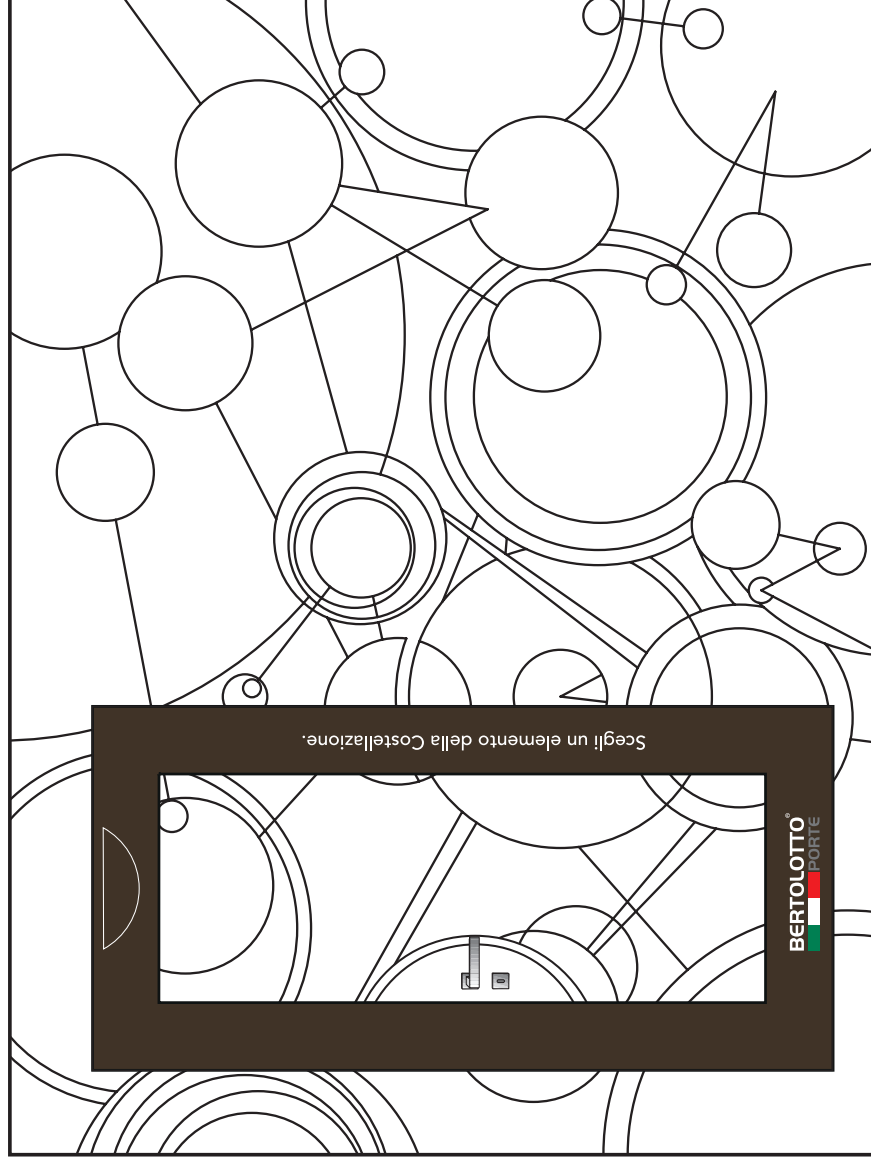

PER CREARE UN AMBIENTE "UNICO" SCEGLI, AIUTANDOTI CON LA DIMA IN CARTONCINO, QUALE PORZIONE DELLA COSTELLAZIONE MEGLIO RAPPRESENTA LA TUA INDIVIDUALITÀ. BERTOLOTTO LA RIPRODurrÀ SU PORTE O PARETI SCORREVOLI, CON PANNELLI MODULABILI FINO A DIMENSIONI MASSIME DI 290 X 90 CM. TUTTI I MODELLI VENGONO REALIZZATI SU MISURA, COME UN ABITO, SOLO PER TE. LA DIMA HA LO STESSO RAPPORTO, IN SCALA RIDOTTA, DELLE DIMENSIONI DI UNA PORTA STANDARD 210 X 80 CM.

TO CREATE AN UNIQUE SPACE, YOU CAN CHOOSE, WITH THE HELP OF THE CARD BOARD TEMPLATE, WHICH PART OF COSTELLAZIONI BEST REPRESENTS YOUR PERSONALITY. BERTOLOTTO WILL REPRODUCE IT ON HINGED OR SLIDING DOORS WITH MODULAR PANELS, UP TO MAXIMUM DIMENSIONS OF 290 X 90 CM. ALL MODELS ARE CUSTOM-MADE JUST FOR YOU. THE TEMPLATE HAS THE SAME RATIO, ON A SMALL SCALE, OF STANDARD DOOR DIMENSION (210 X 80 CM).



Y

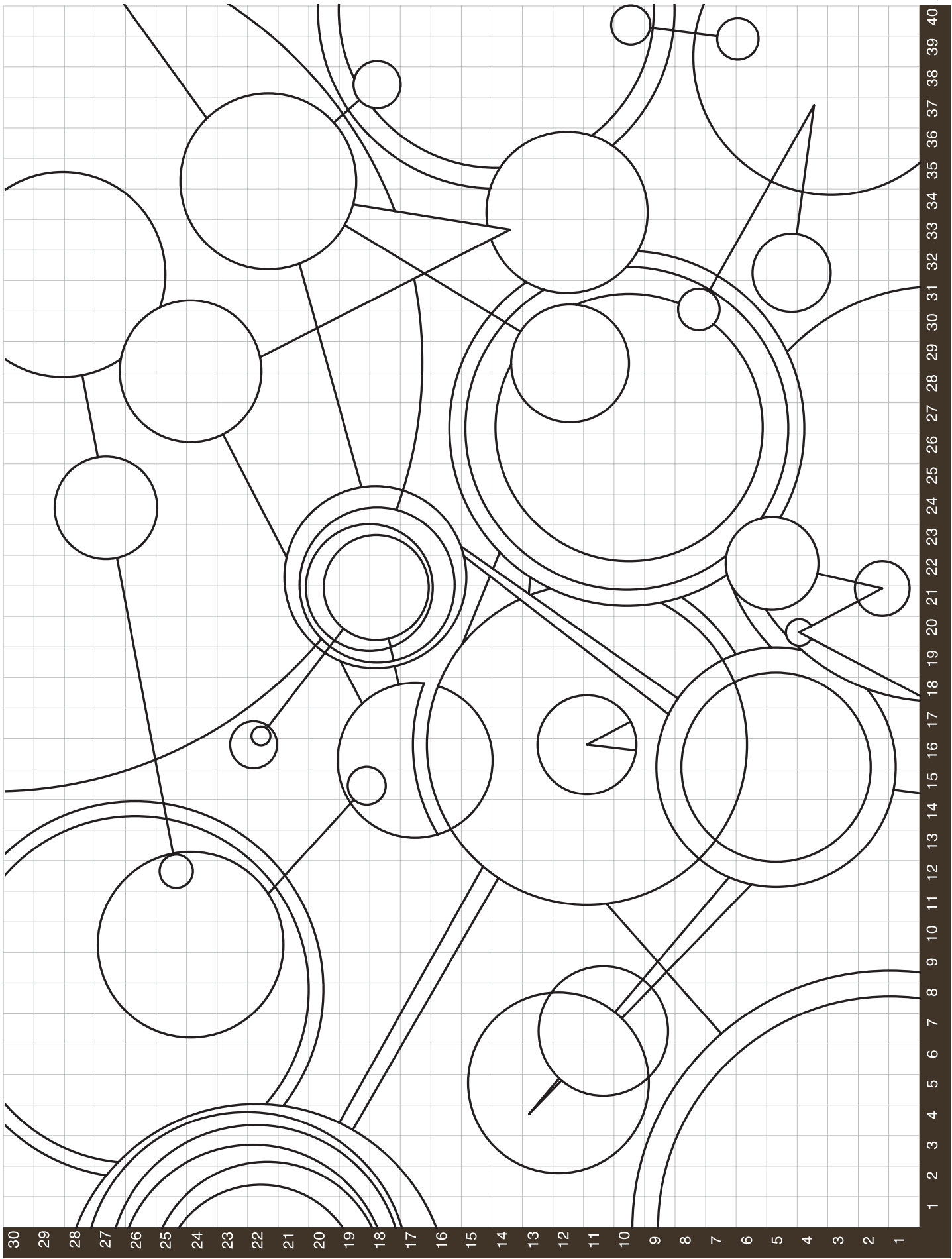

SCEGLI LA PORZIONE DELLA COSTELLAZIONE CHE PREFERISCI  
CHOOSE WHICH PART OF COSTELLAZIONI YOU PREFER

# MODELLI COSTELLAZIONI

COSTELLAZIONI MODELS

## ANTE LACCATE/LACQUERED LEAVES

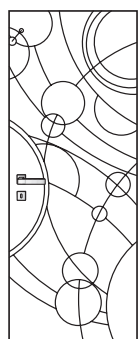

ALTAIR

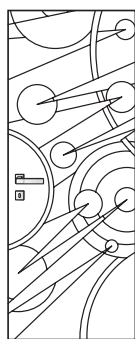

ANDROMEDA

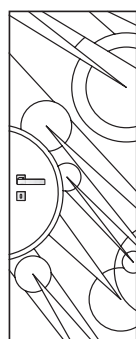

AURIGA

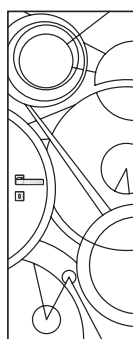

CASSIOPEA

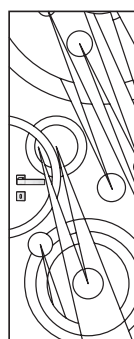

PEGASO

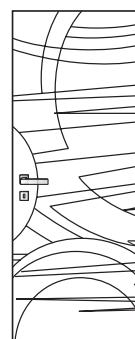

VEGA

## VETRI INCISI/ENGRAVED GLASSES

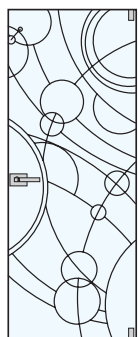

3151

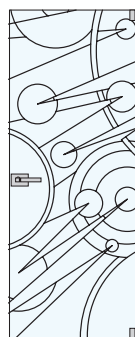

3152

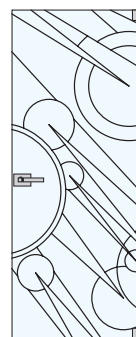

3153

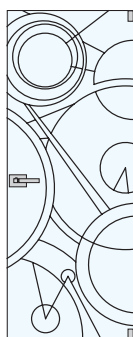

3154

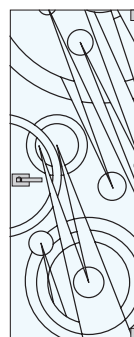

3155

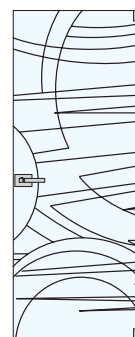

3156



# TIPOLOGIE DI APERTURA

OPENING SYSTEMS

## LEGENDA

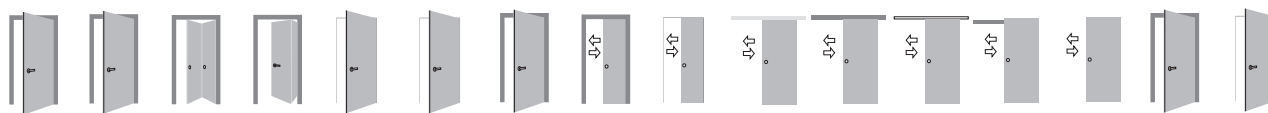

| MODELLO   | Battente | Sky | Piego | Double | Walldoor Minima | Walldoor Massima | Reversa | Scomparsa | Scomparsa Walldoor | Plana | Plana con cover | Steel | Ghost | Phantom | Bidirezionale | Rivestimento blindato |
|-----------|----------|-----|-------|--------|-----------------|------------------|---------|-----------|--------------------|-------|-----------------|-------|-------|---------|---------------|-----------------------|
| ALTAIR    | •        | •   |       |        | •               | •                | •       | •         | •                  | •     | •               | •     | •     | •       | •             | •                     |
| ANDROMEDA | •        | •   |       |        | •               | •                | •       | •         | •                  | •     | •               | •     | •     | •       | •             | •                     |
| AURIGA    | •        | •   |       |        | •               | •                | •       | •         | •                  | •     | •               | •     | •     | •       | •             | •                     |
| CASSIOPEA | •        | •   |       |        | •               | •                | •       | •         | •                  | •     | •               | •     | •     | •       | •             | •                     |
| PEGASO    | •        | •   |       |        | •               | •                | •       | •         | •                  | •     | •               | •     | •     | •       | •             | •                     |
| VEGA      | •        | •   |       |        | •               | •                | •       | •         | •                  | •     | •               | •     | •     | •       | •             | •                     |
| 3151      | •        |     |       |        |                 |                  |         | •         | •                  | •     | •               | •     |       | •       |               |                       |
| 3152      | •        |     |       |        |                 |                  |         | •         | •                  | •     | •               | •     |       | •       |               |                       |
| 3153      | •        |     |       |        |                 |                  |         | •         | •                  | •     | •               | •     |       | •       |               |                       |
| 3154      | •        |     |       |        |                 |                  |         | •         | •                  | •     | •               | •     |       | •       |               |                       |
| 3155      | •        |     |       |        |                 |                  |         | •         | •                  | •     | •               | •     |       | •       |               |                       |
| 3156      | •        |     |       |        |                 |                  |         | •         | •                  | •     | •               | •     |       | •       |               |                       |

TUTTI I MODELLI COSTELLAZIONI POTREBBERO AVERE LE INCISIONI IN CORRISPONDENZA DI MANIGLIERIA, CATENELLA E SPIONCINO DELLA PORTA BLINDATA. DECLINIAMO OGNI RESPONSABILITÀ PER CATTIVA ESTETICA.

ALL THE MODELS CAN BE ENGRAVED NEAR THE HANDLES, PEEP HOLE ETC. OF REINFORCED DOORS. WE DECLINE ALL RESPONSIBILITY FOR UNSATISFACTORY AESTHETICS

## NOVITA'

### SCORREVOLE PHANTOM VETRO

SCORRIMENTO INVISIBILE A PORTA APERTA O CHIUSA

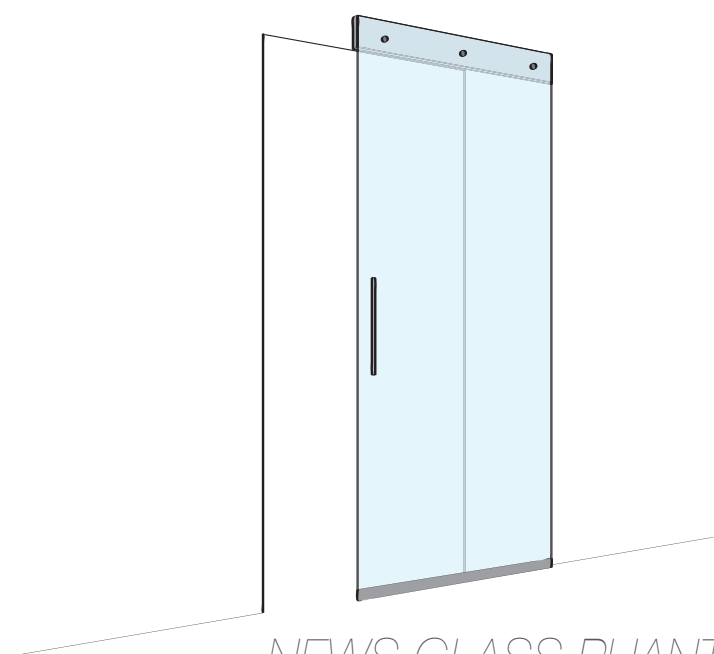

NEWS GLASS PHANTOM SLIDING DOOR  
INVISIBLE SLIDING SYSTEM BOTH WITH OPEN OR CLOSED DOOR

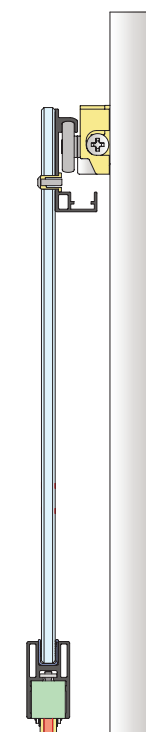

# COLORI LACCATO

SCEGLI IL COLORE CHE PREFERISCI

*LACQUERED COLOURS*

*CHOOSE YOUR FAVORITE COLOR*

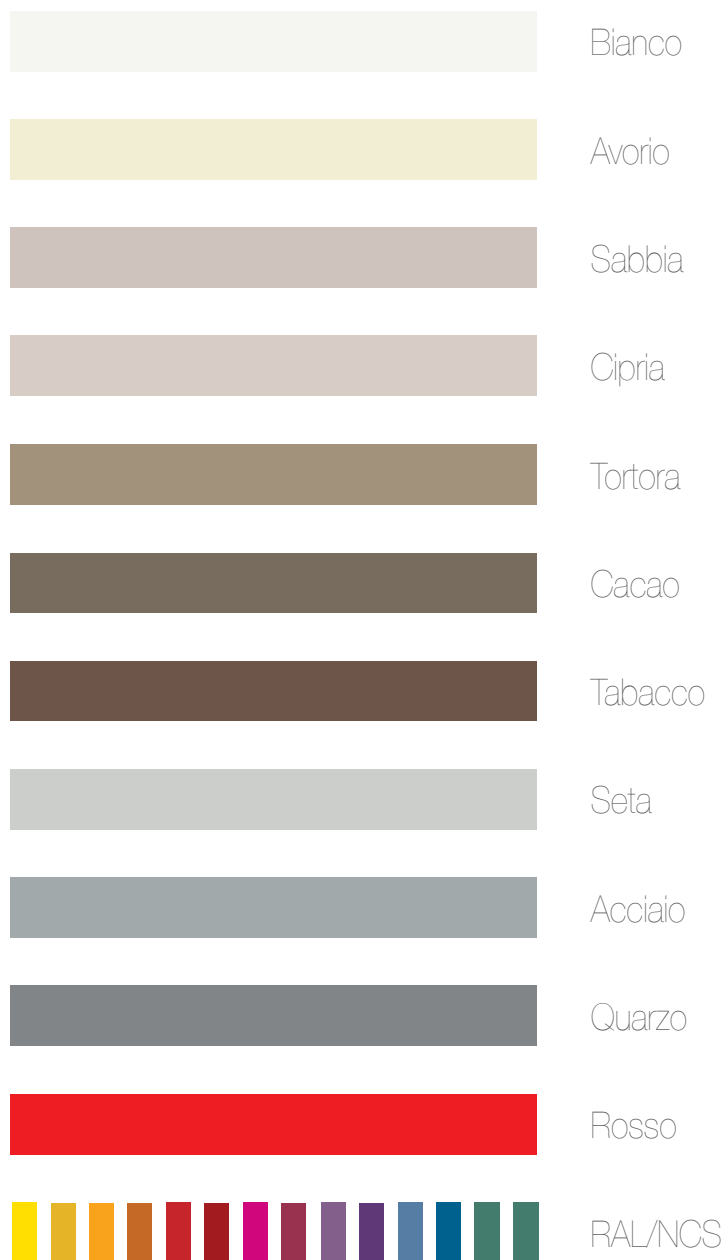

## PULIZIA PRODOTTI LACCATI OPACHI

UTILIZZARE UN PANNO MORBIDO INUMIDITO CON ACQUA TIEPIDA.

*CLEANING MAT LACQUERED PRODUCTS*

*USE A SOFT CLOTH DAMPENED WITH WARM WATER.*



# VETRI

GLASSES



SATINATO BIANCO



TRASPARENTE



I VETRI DI SICUREZZA TEMPERATI  
ORIGINALI BERTOLOTTO  
THE ORIGINAL SAFETY TEMPERED  
GLASSES BERTOLOTTO



SATINATO VERDE



SATINATO GRIGIO



SATINATO BRONZO



SATINATO BLU



TRASPARENTE VERDE



TRASPARENTE GRIGIO



TRASPARENTE BRONZO

## PULIZIA VETRI

CLEANING GLASSES

NON UTILIZZARE DETERGENTI ABRASIVI, SOLVENTI, PRODOTTI SCHIUMOSI O LUCIDANTI CHE POTREBBERO LASCIARE ALONI. UTILIZZARE ACQUA CALDA CON PANNINO MORBIDO. IN CASO DI GRAFFI, AMMACCATURE, DANNEGGIAMENTI FORTUITI O ANOMALIE DEL FUNZIONAMENTO RIVOLGERSI AL NOSTRO UFFICIO TECNICO PER CONSIGLI E INTERVENTI. EVITARE IL "FAI DA TE".

DO NOT USE ABRASIVE DETERGENTS, SOLVENTS, FOAMING SUBSTANCES, POLISHING PRODUCTS THAT COULD LEAVE HALOS. DO USE HOT WATER WITH A SOFT RAG. IN THE EVENT OF SCRATCHES, DENTS, ACCIDENTAL DAMAGES OR ANOMALIES, PLEASE CONTACT OUR TECHNICAL DEPARTMENT FOR SUGGESTIONS AND INTERVENTIONS. DO AVOID DO-IT-YOURSELF SOLUTIONS.

# MANIGLIE

HANDLES



ARA  
CROMO LUCIDO



BIBLO  
CROMO LUCIDO



NAVY  
CROMO LUCIDO



MIAMI  
CROMO LUCIDO



BILBAO CRISTAL  
CROMO LUCIDO



CAROL  
CROMO SATINATO



PARROT  
CROMO LUC./SAT.



MONDRIAN  
CROMO SATINATO



CODA  
CROMO LUC./SAT.



GENEVE  
CROMO SATINATO



TECH  
CROMO SATINATO



TIEMPO  
CROMO SATINATO



VERTIGO  
CROMO LUCIDO



NAVY LINE  
CROMO SATINATO



SPY  
CROMO LUC./SAT.



WINTER  
CROMO LUC./SAT.



HELIOS  
CROMO LUCIDO



HELIOS CRISTAL  
CROMO LUCIDO



HELIOS LUX  
CROMO LUCIDO



STILO 2  
CROMO LUC./SAT.



FLY  
CROMO LUCIDO



FLY CRISTAL  
CROMO LUCIDO



PALMY  
CROMO SATINATO



# MANIGLIE CON ROSETTA MINI

HANDLES  
WITH ROSETTA MINI



ARA  
CROMO LUCIDO



BIBLO  
CROMO LUCIDO



VIRGIN  
CROMO LUCIDO



ZEFIRO  
CROMO LUC./SAT.



BILBAO CRISTAL  
CROMO LUCIDO



CAROL  
CROMO SATINATO



PARROT  
CROMO LUC./SAT.



MONDRIAN  
CROMO SATINATO



CODA  
CROMO LUC./SAT.



GENEVE  
CROMO SATINATO



TECH  
CROMO SATINATO



TIEMPO  
CROMO SATINATO



VERTIGO  
CROMO LUCIDO



NAVY LINE  
CROMO SATINATO



SPY  
CROMO LUC./SAT.



WINTER  
CROMO LUC./SAT.



PALMY  
CROMO SATINATO



STILO 2  
CROMO LUC./SAT.

# MANIGLIONI

*HANDLE BARS*



LINEAR



CODA



STILUS



TODO



# SERRATURA PORTE A BATTENTE

LOCKSET  
FOR HINGED DOORS



MAGNETICA  
CON CHIAVE



MAGNETICA  
CON YALE



MAGNETICA  
CON LIBERO OCCUPATO



SERRATURA CON  
SCROCCO A RULLO

# ROSETTE PORTE A BATTENTE

DIFFERENZE FORMALI E FUNZIONALI. ROSETTA TONDA O QUADRA E TRE TIPI DI CHIAVE: PER OGNI PORTA A BATTENTE LA CHIUSURA IDEALE.

*ROSAGES  
HINGED DOORS*

*FORMAL AND FUNCTIONAL DIFFERENCES. ROUND OR SQUARE ROSAGE AND 3 DIFFERENT KEY TYPOLOGIES: FOR EACH HINGED DOOR THE PERFECT LOCK.*



ROSETTA MINI  
CON BOCCHETTA FORO CHIAVE



ROSETTA TONDA  
CON CHIAVE



ROSETTA KUADER  
CON CHIAVE



ROSETTA MINI  
CON BOCCHETTA FORO YALE



ROSETTA TONDA  
CON YALE



ROSETTA KUADER  
CON YALE



ROSETTA MINI  
CON BOCCHETTA E NOTTOLINO L/O



ROSETTA TONDA  
CON LIBERO/OCCUPATO



ROSETTA KUADER  
CON LIBERO/OCCUPATO





# UNGHiate E NOTTOLINI L/O

## PORTE SCORREVOLI

UNGHIA TA TONDA, KUADER, TONDA CON L/O, KUADER CON L/O, INKA, BIG: SEI SOLUZIONI PER LE PORTE SCORREVOLI A SCOMPARS A. VENGONO MONTATE A FILO PORTA, PER PERMETTERE L'APERTURA COMPLETA. E PER IL "RECUPERO" IN BATTUTA IL "DITALE" DI TRASCINAMENTO, CON FINITURA E FORMA ABBINATE.

### ROSAGES SLIDING DOORS

ROUND FLUSH PULL, KUADER, ROUND WITH, WC LOCK, KUADER WITH WC LOCK, INKA, BIG: SIX SOLUTIONS FOR POCKET DOORS. They ARE MOUNTED FLUSH TO THE LEAF TO ALLOW COMPLETE OPENING. ON THE RABBET A DRAG HOLE IS INSTALLED WITH MATCHING FINISH AND SHAPE.



KIT UNGHIA TA TONDA  
cromo satinato



KIT L/O TONDA  
cromo satinato



KIT UNGHIA TA INKA  
cromo satinato

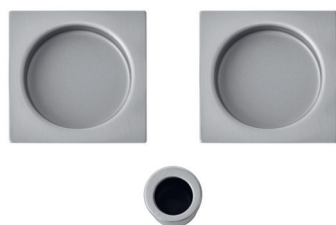

KIT UNGHIA TA KUADER  
cromo satinato



KIT L/O KUADER  
cromo satinato



KIT UNGHIA TA BIG  
cromo satinato



MANIGLIA SLIDE  
cromo satinato

# SERRATURA

## PORTE SCORREVOLI

SERRATURA PORTE SCORREVOLI A SCOMPARS A, GARANTITE DA UN COLOSSO DELLA FERRAMENTA. OGNI SISTEMA DI APERTURA SI COMPLETA CON LA SERRATURA IDEALE.

### LOCKSET SLIDING DOORS

OUR LOCKS FOR POCKET DOORS ARE GUARANTEED BY A MAJOR HARDWARE SUPPLIER. EVERY DOORSET IS COMPLETED WITH THE BEST POSSIBLE LOCK.



SERRATURA  
SCIVOLA T

# TELAJ

SCEGLI IL TELAIO CHE FA PER TE

FRAMES

SCEGLI IL TELAIO CHE FA PER TE



TR/L8  
DI SERIE



T/REV



T/SOR

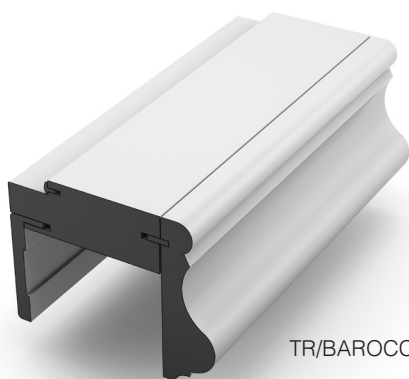

TR/BAROCCO



TR/LINEAR

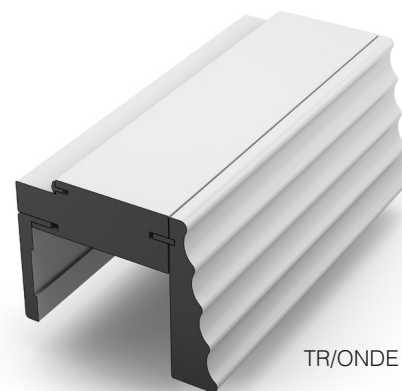

TR/ONDE

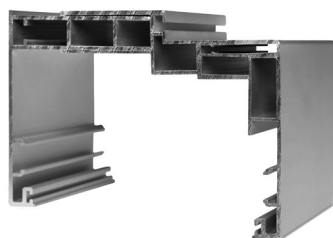

TALL



# PARTICOLARI CERNIERE E SERRATURE

*PARTICULARS  
HINGES AND LOCKS*



SERRATURA MAGNETICA



CERNIERE A SCOMPARSA REGOLABILI

# FERMAPORTA

NELLA GAMMA DI ACCESSORI I FERMAPORTA DA MONTARE A PAVIMENTO:  
5 DIVERSI DESIGN E 4 FINITURE, DA ABBINARE ALLE MANIGLIE E ALL'AMBIENTE.

## *DOOR STOP*

*IN OUR RANGE OF ACCESSORIES WE ALSO OFFER DOORSTOPS TO BE INSTALLED IN THE  
FLOOR: 5 DIFFERENT DESIGN PIECES TO MATCH WITH HANDLES AND SURROUNDINGS.*



LANCIA



VERSO



CASCO



CONO

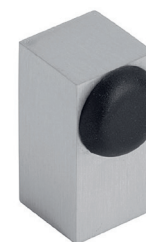

BOX

COSTELLAZIONI  
II. EDIZIONE Aprile 2016

Bertolotto Porte S.p.A. si riserva il diritto di apportare, senza preavviso, ogni modifica volta al miglioramento funzionale e qualitativo dei prodotti. Le informazioni e i disegni rappresentati in questo catalogo, oltre ad avere carattere puramente illustrativo sono suscettibili di variazioni. I campioni di colori e materiali presentati in questo stampato hanno un valore indicativo compatibilmente con i limiti di riproduzione e stampa.

© PROPRIETÀ DI Bertolotto Porte S.p.A. - TUTTI I DIRITTI RISERVATI - I marchi e gli altri segni distintivi, i testi, le fotografie, i disegni ed i modelli, i prodotti e gli altri materiali riportati nella presente brochure e tutti i diritti di proprietà intellettuale ed industriale ad essi relativi costituiscono proprietà riservata

di Bertolotto Porte S.p.A. È vietata la riproduzione, copia, imitazione, pubblicazione, diffusione, distribuzione, elaborazione e qualsiasi uso, anche parziale, nella pubblicità, sui prodotti, confezioni, materiali illustrativi o pubblicitari, siti internet, nelle attività di marketing e commerciali ed ogni altro uso, senza la preventiva autorizzazione scritta di Bertolotto Porte S.p.A.

Bertolotto Porte S.p.A. We reserve the right to change, without notice, any modification to the improvement functional and quality of the products. The information and drawings in this catalog, as well as have purely illustrative are subject to change. Samples of colors and materials presented in this publication are indicative consistent with the limitations of reproduction and printing.

© PROPERTIES OF Bertolotto Porte S.p.A. - ALL RIGHTS RESERVED - Trademarks and other distinctive signs, texts, photographs, drawings and models, products and other materials contained in this brochure and all the intellectual and industrial property rights relating thereto are copyrighted by Bertolotto Porte S.p.A. It's forbidden their reproduction, copying, imitation, publication, dissemination, distribution, processing and use, even partial, advertising, products, packaging, artworks or advertising, websites, marketing activities and sales and all other use without the prior written permission of Bertolotto Porte S.p.A.

BERTOLOTTTO PORTE S.p.A  
CIRCONVALLAZIONE G. GIOLITTI, 43/45  
12030 TORRE S. GIORGIO • CN • ITALY  
TEL. +39.0172.91.28 • FAX +39.0172.912.800  
www.bertolotto.com • staff@bertolotto.com